



National  
Qualifications  
2023

**X807/77/02**

**Biology**  
**Section 1 — Questions**

THURSDAY, 27 APRIL

1:00 PM – 4:00 PM

Instructions for the completion of Section 1 are given on *page 02* of your question and answer booklet X807/77/01.

Record your answers on the answer grid on *page 03* of your question and answer booklet.

Before leaving the examination room you must give your question and answer booklet to the Invigilator; if you do not, you may lose all the marks for this paper.



\* X 8 0 7 7 7 0 2 \*

SECTION 1 — 20 marks

Attempt ALL questions

1. The proteome is
- A all the genes expressed as proteins
  - B the entire set of proteins expressed by the genome
  - C the number of proteins expressed due to alternative RNA splicing
  - D the number of proteins expressed due to alternative RNA splicing and post-translational modification.
2. Transmembrane proteins carry a signal sequence, which halts translation and directs the ribosome synthesising the protein to dock with the
- A plasma membrane
  - B endoplasmic reticulum
  - C transport vesicle
  - D golgi apparatus.

3. Cell components can be separated by a technique called differential centrifugation.

This technique uses a series of centrifugation steps at specific centrifugation forces (g) for a given time. After each step, the supernatant is removed and the cell components in the pellet identified. The supernatant is re-centrifuged at a higher centrifugation force for a longer time.

The table gives information about a differential centrifugation experiment.

Step	Centrifuge conditions		Cell component(s) in pellet
	Force (g)	Time (minutes)	
1	600	10	nucleus, cytoskeleton
2	15 000	15	mitochondria
3	100 000	60	plasma membrane, endoplasmic reticulum fragments

Plasma membrane would be present in the supernatant of which centrifugation step(s)?

- A 1 only
- B 2 only
- C 1 and 2 only
- D 3 only

4. Which row in the table is correct for positive modulators?

	<b>Binding site</b>	<b>Effect of binding on enzyme affinity for substrate</b>
A	allosteric	increases
B	active	increases
C	allosteric	decreases
D	active	decreases

5. Which row in the table describes events in signalling by the hormone insulin?

	<b>Location of insulin binding site</b>	<b>Mechanism of signal transduction</b>
A	intracellular	G-protein activation
B	intracellular	phosphorylation
C	extracellular	G-protein activation
D	extracellular	phosphorylation

[Turn over

6. A newly identified drug designed to treat cancer by inhibiting cell cycle progression was tested on cancer cells *in vitro*. The distribution of the cancer cells across the different phases of the cell cycle was then investigated by measuring the DNA content of the cells. Results for untreated cells are shown in **Figure 1** and for treated cells in **Figure 2**. DNA content is displayed with arbitrary units where  $2n$  units represents the DNA content of a non-dividing diploid cell.

**Figure 1**

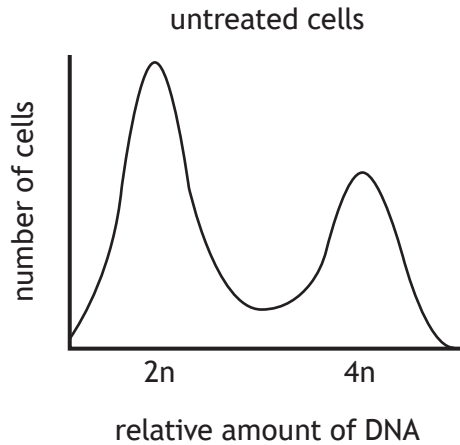

**Figure 2**

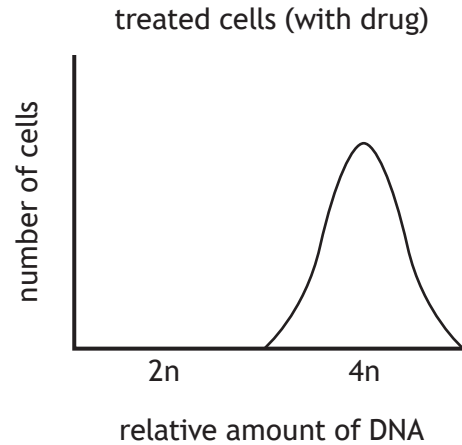

At which phase(s) of the cell cycle does this drug act?

- A G1 only
  - B S only
  - C G1 and G2
  - D G2 or M
7. The three Rs of replacement, reduction and refinement are used in animal studies to avoid, reduce or minimise the harm to animals.
- Which of the following is an example of replacement?
- A Use of most appropriate anaesthetic regimes for pain relief during procedures.
  - B Smaller mammals such as mice or rats instead of larger mammals.
  - C Substitution of *in vivo* studies with tissue culture to test the effect of a new drug.
  - D Less invasive techniques instead of surgical techniques.
8. Active cyclin-CDK complexes regulate the cell cycle by
- A phosphorylation of specific proteins
  - B proteolytic cleavage of specific proteins
  - C dephosphorylation of specific proteins
  - D acting as transcription factors.

9. Leucism is the lack of melanin (dark) pigments in all or part of the skin, hair, or feathers. It is found in many animal species, and in birds it results in the partial or complete absence of melanin in one or more feathers. The figures show data from a study of leucism in a population of red-necked nightjars conducted in a national park in Spain from 2016–2020. Nightjars are considered adults when they are two years old and over.

Figure 1

Year	Number leucistic		Total number		Frequency (%)	
	Males	Females	Males	Females	Males	Females
2016	2	2	64	107	3.13	1.87
2017	2	4	74	98	2.70	4.08
2018	2	0	75	108	2.67	0.00
2019	3	3	78	72	3.85	4.19
2020	0	5	43	88	0.00	5.68

Figure 2

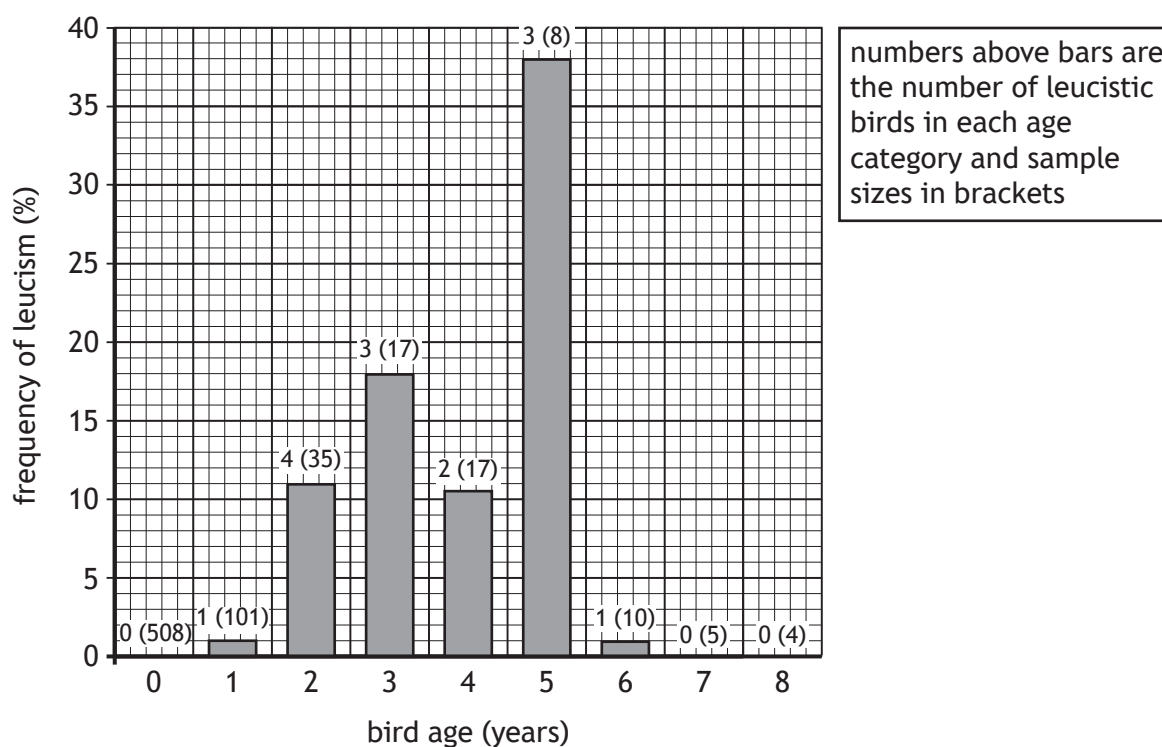

Which of the following conclusions about leucism in nightjars **cannot** be drawn from the data shown?

- A Leucism occurs at similar frequencies overall in males and females.
- B The frequency of leucism is low in older birds because leucistic individuals have a greater risk of predation.
- C The frequency of leucism shows considerable annual variation.
- D The frequency of leucism increases markedly from the juvenile to the adult stage.

10. The alveoli of vertebrate lungs have thin walls, constructed of a single layer of epithelial cells, which allow rapid diffusion of gases. The rate of diffusion of oxygen across exchange surfaces can be calculated using the following formula:

$$\text{Rate} = P \times A \times \frac{(C_1 - C_2)}{T}$$

where: P is the permeability constant

A is the surface area

$C_1$  is the higher concentration

$C_2$  is the lower concentration

T is the thickness of the exchange surface.

A section of alveolar epithelium has a surface area of  $2.2 \mu\text{m}^2$  and is  $1.0 \mu\text{m}$  thick. The permeability constant of the epithelium for oxygen is  $0.012 \text{ s}^{-1}$ . The concentration of oxygen on one side of the epithelium is  $2.3 \times 10^{-16} \text{ mol } \mu\text{m}^{-3}$  and the concentration on the other side is  $9.0 \times 10^{-17} \text{ mol } \mu\text{m}^{-3}$ .

What is the rate of diffusion of oxygen across this alveolar epithelium?

- A  $1.8 \times 10^{-1} \text{ mol } \mu\text{m}^{-2} \text{ s}^{-1}$   
 B  $2.3 \times 10^{-16} \text{ mol } \mu\text{m}^{-2} \text{ s}^{-1}$   
 C  $1.8 \times 10^{-18} \text{ mol } \mu\text{m}^{-2} \text{ s}^{-1}$   
 D  $3.7 \times 10^{-18} \text{ mol } \mu\text{m}^{-2} \text{ s}^{-1}$
11. Red-green colour deficiency is a sex-linked condition caused by a recessive allele. The diagram shows the inheritance of this condition in a family.

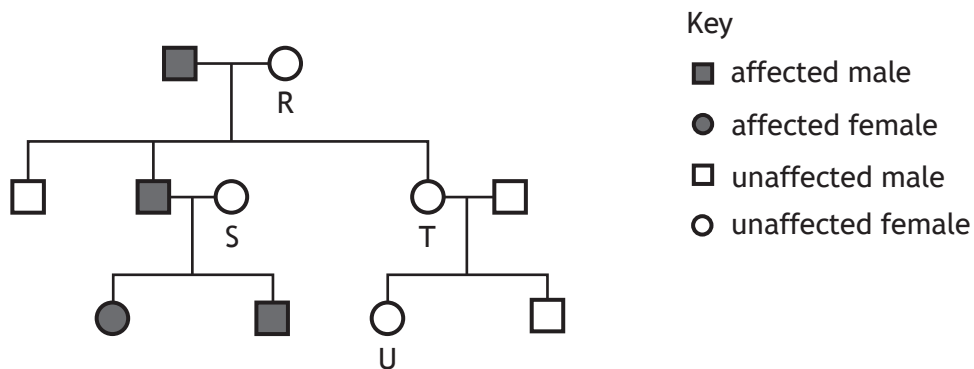

Using the information given in the diagram, which of the females **must** be carriers of red-green colour deficiency?

- A S only  
 B R and S only  
 C R, S and T only  
 D R, S, T and U

12. Steps 1 to 6 describe some events that occur during meiosis. Some terms are represented by the letters J, K, L and M.
1. Chromosomes replicate to form two identical chromatids.
  2. Homologous chromosomes pair up and points of contact form between J chromatids of a homologous pair.
  3. K takes place to form new combinations of alleles of linked genes.
  4. Chromosomes of each homologous pair attach to spindle fibres and separate to opposite poles.
  5. L occurs and two daughter cells form.
  6. Two daughter cells undergo further division separating M chromatids of each chromosome.

Which row in the table identifies J, K, L and M?

	J	K	L	M
A	non-sister	cytokinesis	crossing over	sister
B	sister	crossing over	cytokinesis	non-sister
C	non-sister	crossing over	cytokinesis	sister
D	sister	cytokinesis	crossing over	non-sister

[Turn over

13. Which of the following formulae would allow absolute fitness to be calculated?
- A  $\frac{\text{number of surviving offspring per individual of a particular genotype}}{\text{number of surviving offspring per individual of the most successful genotype}}$
  - B  $\frac{\text{number of surviving offspring per individual of the most successful genotype}}{\text{number of surviving offspring per individual of a particular genotype}}$
  - C  $\frac{\text{frequency of a particular genotype before selection}}{\text{frequency of a particular genotype after selection}}$
  - D  $\frac{\text{frequency of a particular genotype after selection}}{\text{frequency of a particular genotype before selection}}$
14. In pea plants, the allele for yellow peas is dominant to the allele for green peas. A sample of 100 peas contained 84 yellow and 16 green peas. What is the frequency of the yellow allele in this population?
- A 0.36
  - B 0.40
  - C 0.60
  - D 0.84
15. An experiment investigated the effect of an insecticide on local wild bee populations. Scientists sampled each species of bee in proportion to the contribution its population size made to the total number of bees of all species present in the area. What name is given to this type of sampling strategy?
- A Random sampling
  - B Stratified sampling
  - C Systematic sampling
  - D Point count sampling

16. Eukaryotic chromosomes end in repetitive non-coding sequences of DNA called telomeres. Telomeres protect the coding DNA but become shorter with each round of DNA replication. The shortening of telomeres explains why many cells have a limited number of cell divisions and is associated with the ageing processes in organisms. Rapidly dividing cells may use an enzyme called telomerase to increase the lengths of telomeres.

Parasitic infections often increase the rate of cell division.

A student made the following predictions:

1. Parasitic infections can lead to faster ageing.
2. Telomerase activity will be low in cancer cells.
3. There is a positive correlation between telomere length and age.
4. Telomerase activity will be high in yeast cultures where there is a high reproductive rate.

Which of these predictions are consistent with the information given?

- A 1 and 2
- B 1 and 4
- C 2 and 3
- D 3 and 4

[Turn over

17. A student was planning an investigation into the effect of temperature on the rate of respiration in yeast; this was measured using a carbon dioxide probe. As part of their pilot studies, they used the probe to take three readings from one sample.

This would be most useful for checking

- A precision
- B accuracy
- C reliability
- D validity.

18. The diagram shows a boxplot for a set of data.

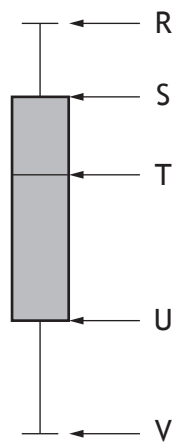

Which statement about the dataset represented by this boxplot is true?

- A T is the mean value
  - B R minus V is the interquartile range
  - C 50% of the data are above U
  - D 75% of the data are below S
19. Which row in the table describes natural killer cells?

	Type of response		Mechanism of action	
	Specific	Non-specific	Induce apoptosis in parasite-infected cells	Use enzymes in lysosomes to digest parasites
A	✓	✗	✓	✗
B	✓	✗	✗	✓
C	✗	✓	✓	✗
D	✗	✓	✗	✓

20. *Trypanosoma gambiense* is a parasite that causes chronic infections in humans and can evade the immune system.

The graph shows the number of trypanosomes over time in a human infected with *Trypanosoma gambiense*.

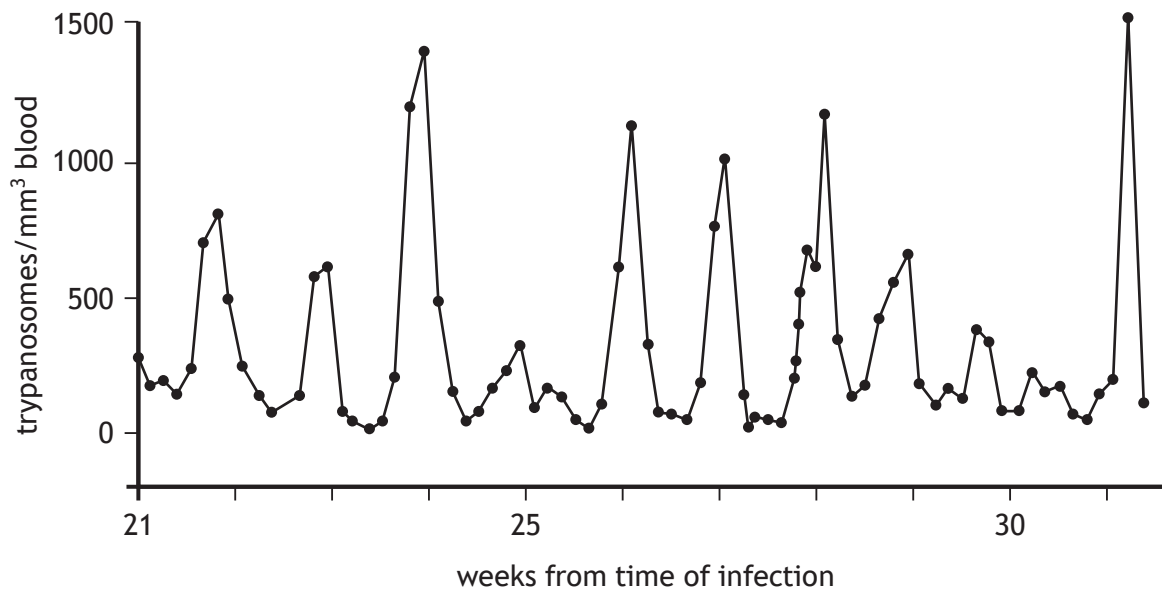

From the data shown, the most probable mechanism used by this parasite to evade the immune system is

- A antigenic variation
- B suppression of the host immune system
- C mimicry of host antigens
- D latency.

[END OF SECTION 1. NOW ATTEMPT THE QUESTIONS IN SECTION 2  
OF YOUR QUESTION AND ANSWER BOOKLET.]

[BLANK PAGE]

DO NOT WRITE ON THIS PAGE