

FOR OFFICIAL USE



National
Qualifications
2016

Mark

X713/77/01

**Chemistry
Section 1 — Answer Grid
and Section 2**

WEDNESDAY, 18 MAY

9:00 AM – 11:30 AM



* X 7 1 3 7 7 0 1 *

Fill in these boxes and read what is printed below.

Full name of centre

Town

Forename(s)

Surname

Number of seat

Date of birth

Day

Month

Year

Scottish candidate number

Reference may be made to the Chemistry Higher and Advanced Higher Data Booklet.

Total marks — 100

SECTION 1 —30 marks

Attempt ALL questions.

Instructions for the completion of Section 1 are given on *Page 02*.

SECTION 2 —70 marks

Attempt ALL questions.

Write your answers clearly in the spaces provided in this booklet. Additional space for answers and rough work is provided at the end of this booklet. If you use this space you must clearly identify the question number you are attempting. Any rough work must be written in this booklet. You should score through your rough work when you have written your final copy.

Use **blue** or **black** ink.

Before leaving the examination room you must give this booklet to the Invigilator; if you do not, you may lose all the marks for this paper.



* X 7 1 3 7 7 0 1 0 1 *

The questions for Section 1 are contained in the question paper X713/77/02.

Read these and record your answers on the answer grid on *Page 03* opposite.

Use **blue** or **black** ink. Do NOT use gel pens or pencil.

1. The answer to each question is **either** A, B, C or D. Decide what your answer is, then fill in the appropriate bubble (see sample question below).
2. There is **only one correct** answer to each question.
3. Any rough working should be done on the additional space for answers and rough work at the end of this booklet.

Sample Question

To show that the ink in a ball-pen consists of a mixture of dyes, the method of separation would be:

- A fractional distillation
- B chromatography
- C fractional crystallisation
- D filtration.

The correct answer is **B** — chromatography. The answer **B** bubble has been clearly filled in (see below).

A	B	C	D
<input type="radio"/>	<input checked="" type="radio"/>	<input type="radio"/>	<input type="radio"/>

Changing an answer

If you decide to change your answer, cancel your first answer by putting a cross through it (see below) and fill in the answer you want. The answer below has been changed to **D**.

A	B	C	D
<input type="radio"/>	<input checked="" type="radio"/>	<input type="radio"/>	<input checked="" type="radio"/>

If you then decide to change back to an answer you have already scored out, put a tick (✓) to the **right** of the answer you want, as shown below:

A	B	C	D	or	A	B	C	D
<input type="radio"/>	<input checked="" type="radio"/>	<input type="radio"/>	<input checked="" type="radio"/>		<input type="radio"/>	<input checked="" type="radio"/>	<input type="radio"/>	<input type="radio"/>



SECTION 1 — Answer Grid



* 0 B J 3 0 A D 1 *

	A	B	C	D		A	B	C	D
1	<input type="radio"/>	<input type="radio"/>	<input type="radio"/>	<input type="radio"/>	16	<input type="radio"/>	<input type="radio"/>	<input type="radio"/>	<input type="radio"/>
2	<input type="radio"/>	<input type="radio"/>	<input type="radio"/>	<input type="radio"/>	17	<input type="radio"/>	<input type="radio"/>	<input type="radio"/>	<input type="radio"/>
3	<input type="radio"/>	<input type="radio"/>	<input type="radio"/>	<input type="radio"/>	18	<input type="radio"/>	<input type="radio"/>	<input type="radio"/>	<input type="radio"/>
4	<input type="radio"/>	<input type="radio"/>	<input type="radio"/>	<input type="radio"/>	19	<input type="radio"/>	<input type="radio"/>	<input type="radio"/>	<input type="radio"/>
5	<input type="radio"/>	<input type="radio"/>	<input type="radio"/>	<input type="radio"/>	20	<input type="radio"/>	<input type="radio"/>	<input type="radio"/>	<input type="radio"/>
6	<input type="radio"/>	<input type="radio"/>	<input type="radio"/>	<input type="radio"/>	21	<input type="radio"/>	<input type="radio"/>	<input type="radio"/>	<input type="radio"/>
7	<input type="radio"/>	<input type="radio"/>	<input type="radio"/>	<input type="radio"/>	22	<input type="radio"/>	<input type="radio"/>	<input type="radio"/>	<input type="radio"/>
8	<input type="radio"/>	<input type="radio"/>	<input type="radio"/>	<input type="radio"/>	23	<input type="radio"/>	<input type="radio"/>	<input type="radio"/>	<input type="radio"/>
9	<input type="radio"/>	<input type="radio"/>	<input type="radio"/>	<input type="radio"/>	24	<input type="radio"/>	<input type="radio"/>	<input type="radio"/>	<input type="radio"/>
10	<input type="radio"/>	<input type="radio"/>	<input type="radio"/>	<input type="radio"/>	25	<input type="radio"/>	<input type="radio"/>	<input type="radio"/>	<input type="radio"/>
11	<input type="radio"/>	<input type="radio"/>	<input type="radio"/>	<input type="radio"/>	26	<input type="radio"/>	<input type="radio"/>	<input type="radio"/>	<input type="radio"/>
12	<input type="radio"/>	<input type="radio"/>	<input type="radio"/>	<input type="radio"/>	27	<input type="radio"/>	<input type="radio"/>	<input type="radio"/>	<input type="radio"/>
13	<input type="radio"/>	<input type="radio"/>	<input type="radio"/>	<input type="radio"/>	28	<input type="radio"/>	<input type="radio"/>	<input type="radio"/>	<input type="radio"/>
14	<input type="radio"/>	<input type="radio"/>	<input type="radio"/>	<input type="radio"/>	29	<input type="radio"/>	<input type="radio"/>	<input type="radio"/>	<input type="radio"/>
15	<input type="radio"/>	<input type="radio"/>	<input type="radio"/>	<input type="radio"/>	30	<input type="radio"/>	<input type="radio"/>	<input type="radio"/>	<input type="radio"/>



* X 7 1 3 7 7 0 1 0 3 *

[BLANK PAGE]

DO NOT WRITE ON THIS PAGE



* X 7 1 3 7 7 0 1 0 4 *

[Turn over for next question

DO NOT WRITE ON THIS PAGE



* X 7 1 3 7 7 0 1 0 5 *

SECTION 2 — 70 marks

Attempt ALL questions

1. Ethene can be hydrated to produce ethanol.

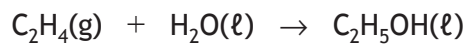

Compound	Standard free energy of formation, ΔG° (kJ mol ⁻¹)	Standard enthalpy of formation, ΔH_f° (kJ mol ⁻¹)
Ethene	68	52
Water	-237	-286
Ethanol	-175	-278

- (a) For the hydration of ethene, use the data in the table to calculate:

(i) the standard enthalpy change, ΔH° , in kJ mol⁻¹; 1

(ii) the standard entropy change, ΔS° , in J K⁻¹ mol⁻¹. 3

- (b) Calculate the temperature, in K, at which this reaction just becomes feasible. 2



2. In the periodic table, period 2 is comprised of the elements lithium to neon. The following table shows two of the quantum numbers for all ten electrons in a neon atom.

<i>Electron</i>	<i>Principal quantum number, n</i>	<i>Angular momentum quantum number, l</i>
1	1	0
2	1	0
3	2	0
4	2	0
5	2	1
6	2	1
7	2	1
8	2	1
9	2	1
10	2	1

- (a) Write the electronic configuration for neon in terms of s and p orbitals. 1
- (b) The angular momentum quantum number, l , is related to the shape of an orbital.
Draw the shape of an orbital when l has a value of 1. 1
- (c) The magnetic quantum number, m , is related to the orientation of an orbital in space.
State the values of m for the orbital which contains the tenth electron. 1



[BLANK PAGE]

DO NOT WRITE ON THIS PAGE



* X 7 1 3 7 7 0 1 0 8 *

3. Iron can form a variety of complexes with different ligands. Each complex has different properties.

(a) Some iron complex ions are paramagnetic. Paramagnetic substances are substances that are weakly attracted by a magnetic field.

Paramagnetism is caused by the presence of unpaired electrons.

In both $[\text{Fe}(\text{H}_2\text{O})_6]^{2+}$ and $[\text{Fe}(\text{CN})_6]^{4-}$, the Fe^{2+} ion has six d-electrons, but only $[\text{Fe}(\text{H}_2\text{O})_6]^{2+}$ is paramagnetic.

(i) Complete the d-orbital box diagram for the complex ion $[\text{Fe}(\text{CN})_6]^{4-}$. 1

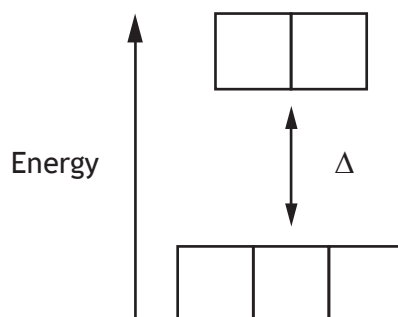

(An additional diagram, if required, can be found on *Page 28*)

(ii) The relative ability of a ligand to split the d-orbitals when forming a complex ion is given by the spectrochemical series.

The spectrochemical series for some ligands is shown below.

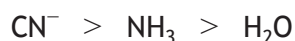

The $[\text{Fe}(\text{H}_2\text{O})_6]^{2+}$ ion has unpaired electrons and is therefore paramagnetic.





Explain how unpaired electrons can arise in this complex ion. 2

(iii) Explain why all of the complex ions formed by the Fe^{3+} ion are paramagnetic. 1

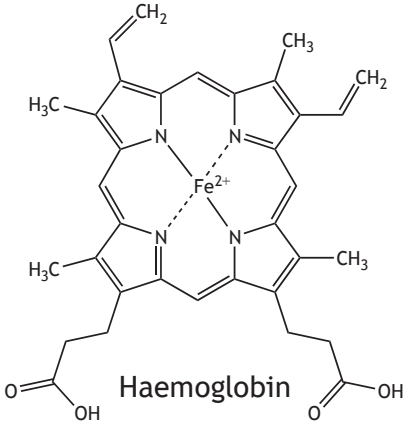

3. (continued)

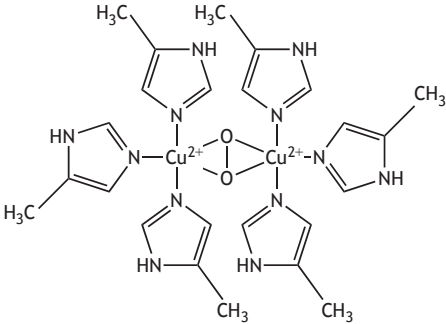
(b) Human blood is red due to the presence of haemoglobin bonded to oxygen. Other animals have different coloured blood due to the presence of different complex ions bonded to oxygen.

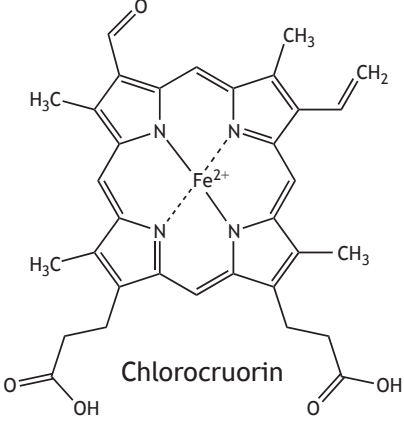
Animal	Complex ion	Colour of blood
 Human	 Haemoglobin	RED
 Spider	 Oxyhaemocyanin	BLUE
 Leech	 Chlorocruorin	GREEN

(i) State the co-ordination number of the Fe^{2+} ion in haemoglobin.

1



3. (b) (continued)

(ii) Spiders' blood contains the oxyhaemocyanin complex ion. Oxyhaemocyanin contains copper ions.

Suggest an analytical technique that could be used to determine the presence of copper ions in spiders' blood.

1

(iii) Using your knowledge of chemistry, comment on why these animals have different coloured blood.

3

[Turn over



* X 7 1 3 7 7 0 1 1 1 *

4. As part of an Advanced Higher Chemistry project, a student determined the chloride ion concentration of seawater by two different methods.

Volumetric method

A sample of seawater was titrated with standard silver nitrate solution.

Gravimetric method

A sample of seawater was reacted with standard silver nitrate solution to form a precipitate. The precipitate was collected by filtration and weighed.

- (a) For the volumetric method, a 0.1 mol l^{-1} standard solution of silver nitrate was prepared by following the instructions below.

1. Dry 5 g of silver nitrate for 2 hours at 100°C and allow to cool.
2. Weigh accurately approximately 4.25 g of solid silver nitrate.
3. Use this sample to prepare 250 cm^3 of standard silver nitrate solution.

- (i) State what is meant by “weigh accurately approximately”
4.25 g of solid silver nitrate.

1

- (ii) Outline how the student would have prepared the standard silver nitrate solution.

2

- (iii) Samples of the diluted seawater were titrated and the average titre was found to be 3.9 cm^3 .

Suggest an improvement the student could make to reduce the uncertainty in the titre value.

1



* X 7 1 3 7 7 0 1 1 2 *

4. (continued)

(b) For the gravimetric method, standard silver nitrate solution was added to a seawater sample to form a precipitate of silver chloride.

(i) Describe how the filtration should have been carried out to ensure a fast means of separating the precipitate from the reaction mixture.

1

(ii) After the precipitate was filtered, the filtrate was tested with a few drops of silver nitrate solution.

Suggest why the student tested the filtrate in this way.

1

(c) The student also planned to carry out an analysis of chloride ion concentration in fresh river water.

Explain why the volumetric method, rather than the gravimetric method, would be more appropriate for the analysis of chloride ion concentration in fresh river water.

1

[Turn over



* X 7 1 3 7 7 0 1 1 3 *

5. Mandelic acid, 2-hydroxy-2-phenylethanoic acid, is a component of skin care products.

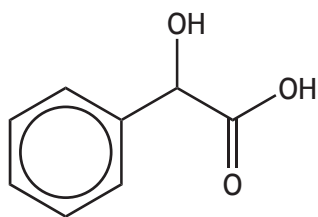

mandelic acid

- (a) Mandelic acid is a weak acid.

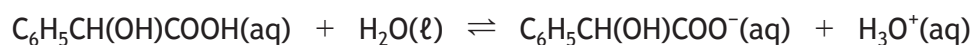

Write the expression for the dissociation constant, K_a , for mandelic acid. 1

- (b) A 100 cm^3 sample of skin care product contained 10.0 g of mandelic acid. The K_a of mandelic acid is 1.78×10^{-4} .

- (i) Calculate the concentration of the mandelic acid, in mol l^{-1} , present in the skin care product. 2

- (ii) Using your answer to (b)(i), calculate the pH of a solution of mandelic acid of this concentration. 3



[Turn over for next question

DO NOT WRITE ON THIS PAGE



* X 7 1 3 7 7 0 1 1 5 *

6. Chlorine is a versatile element which forms a wide range of compounds.

- (a) One example of a compound containing chlorine is vanadium(IV) chloride. It reacts vigorously with water forming a blue solution.

The blue solution absorbs light of wavelength 610 nm.

Calculate the energy, in kJ mol^{-1} , associated with this wavelength.

2

- (b) Chlorine dioxide, ClO_2 , is used in water sterilisation.

An experiment was carried out to determine the kinetics for the reaction between chlorine dioxide and hydroxide ions.



Under certain conditions the following results were obtained.

$[\text{ClO}_2]$ (mol l^{-1})	$[\text{OH}^-]$ (mol l^{-1})	Initial rate ($\text{mol l}^{-1}\text{s}^{-1}$)
6.00×10^{-2}	3.00×10^{-2}	2.48×10^{-2}
1.20×10^{-1}	3.00×10^{-2}	9.92×10^{-2}
1.20×10^{-1}	9.00×10^{-2}	2.98×10^{-1}

- (i) Determine the order of reaction with respect to:

(A) ClO_2

1

(B) OH^-

1



MARKS

DO NOT
WRITE IN
THIS
MARGIN

6. (b) (continued)

(ii) Write the overall rate equation for the reaction.

1

(iii) Calculate the value for the rate constant, k , including the appropriate units.

2



* X 7 1 3 7 7 0 1 1 7 *

7. Aldehydes and ketones can exist in two forms, a keto form and an enol form. For example, the aldehyde ethanal exists in equilibrium with its enol form, ethenol.



These two different molecules are known as tautomers.

- (a) State which of the tautomers is the more abundant in this equilibrium. 1
- (b) 3-Methylpentan-2-one is optically active and exists in equilibrium with its enol tautomer.
- (i) Circle the chiral centre on 3-methylpentan-2-one. 1

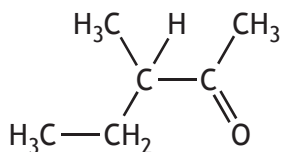

- (ii) Suggest why the optical activity of 3-methylpentan-2-one decreases over time. 1



7. (b) (continued)

(iii) Draw the skeletal formula for 3-methylpentan-2-one.

1

(c) A possible mechanism for acid-catalysed enolisation is shown below, where R, R' and R'' are alkyl groups.

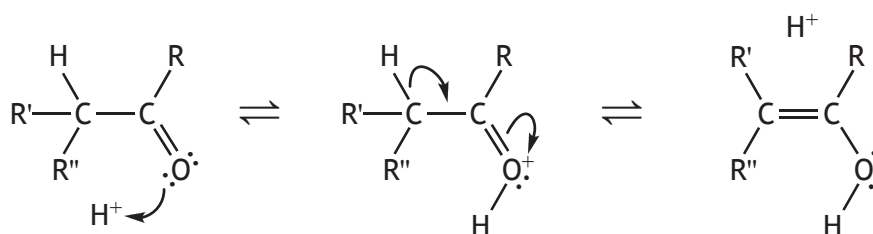

Using structural formulae and curly arrow notation, show a possible mechanism for the acid-catalysed enolisation of 3-methylpentan-2-one.

3



8. Aspirin can be used as a starting material for the synthesis of the drug, salbutamol, which is used in the treatment of asthma. Salbutamol acts as an agonist by stimulating receptors in the lungs.

A possible synthetic route is shown.

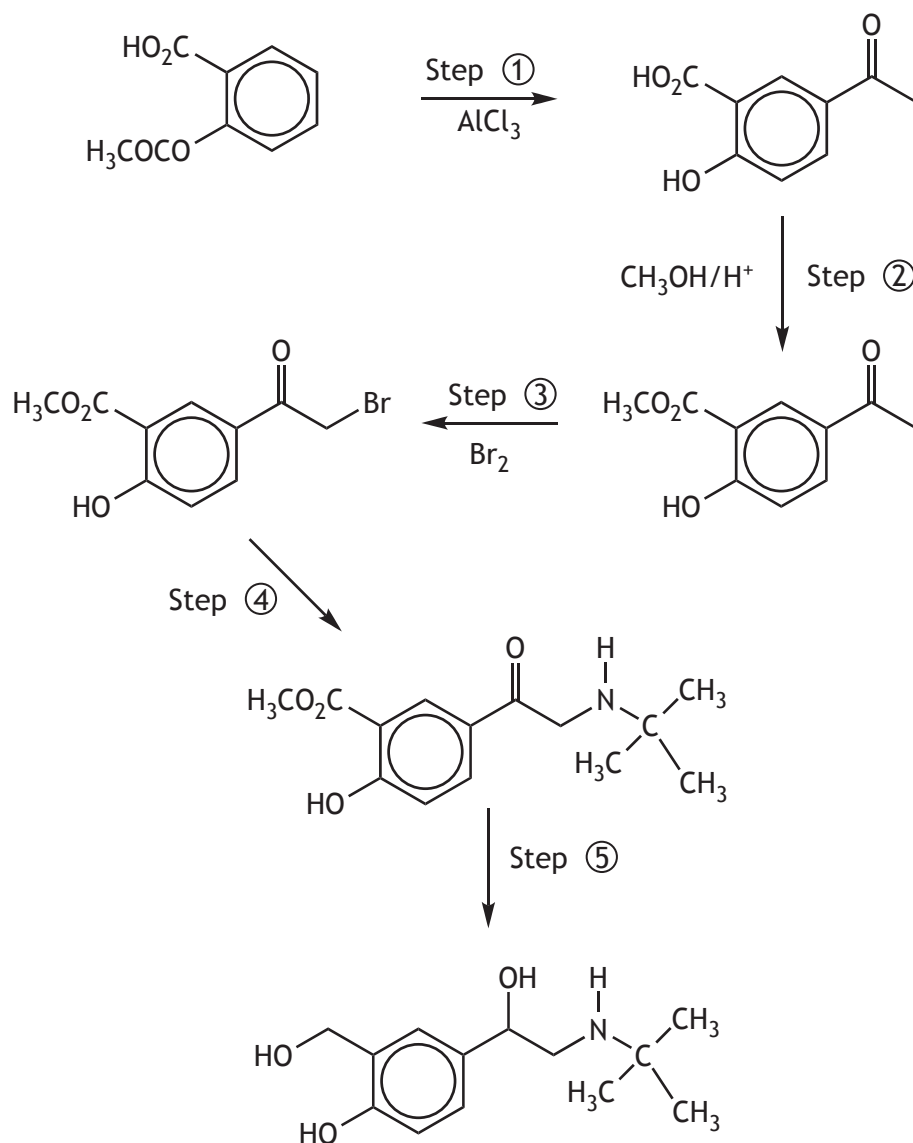

- (a) State what is meant by the term agonist. 1
- (b) Step ① is known as a Fries rearrangement. 1
Suggest the role of AlCl_3 in this rearrangement.



8. (continued)

(c) Suggest a reaction condition required for Step ③. 1

(d) Identify the type of reaction taking place in Step ④. 1

(e) Step ⑤ involves several reactions.
Suggest a suitable reagent that could be used to convert the ketone carbonyl group to the hydroxyl group. 1

[Turn over



* X 7 1 3 7 7 0 1 2 1 *

8. (continued)

- (f) The purity of salbutamol can be determined using a variety of analytical techniques.

Using your knowledge of chemistry, discuss how analytical techniques could be used to determine the purity of salbutamol.

3



* X 7 1 3 7 7 0 1 2 2 *

9. Parabens are used as preservatives in cosmetics, pharmaceutical products and foods. Parabens are esters of 4-hydroxybenzoic acid.

One common paraben used as a food preservative is ethylparaben.

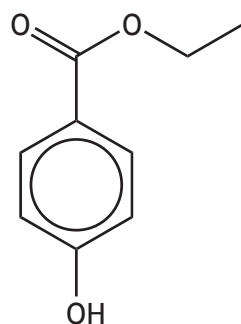

ethylparaben

- (a) Ethylparaben is an aromatic compound containing both sigma and pi bonds.

- | | |
|---|---|
| (i) Write the molecular formula for ethylparaben. | 1 |
| (ii) State the type of hybridisation which is adopted by the carbon atoms in the aromatic ring. | 1 |
| (iii) Describe how pi bonds form. | 1 |

[Turn over



* X 7 1 3 7 7 0 1 2 3 *

9. (continued)

- (b) Another preservative is sodium 4-hydroxybenzoate. It can be prepared by refluxing ethylparaben with sodium hydroxide solution.

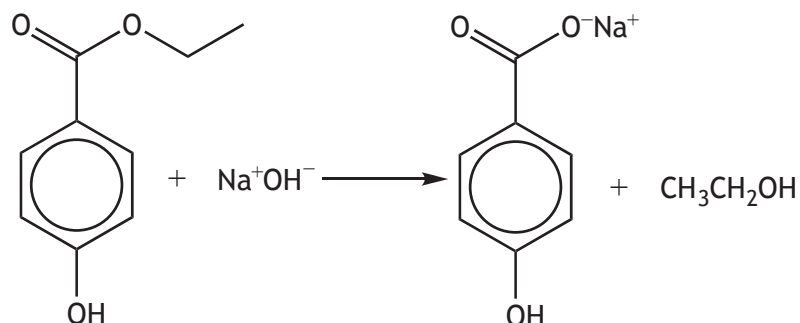

- (i) Complete the diagram below to show how the reaction mixture is heated under reflux.

1

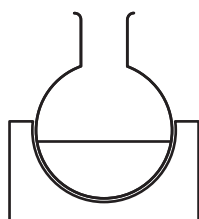

Heating mantle

(An additional diagram, if required, can be found on *Page 28*)

- (ii) At the start of the reaction, two layers were observed in the reaction mixture.

Explain why only one layer was observed when the reaction was complete.

1



9. (b) (continued)

(iii) Explain fully why a solution of the salt sodium 4-hydroxybenzoate has a pH greater than 7. 2

(iv) After refluxing, dilute hydrochloric acid was added to the reaction mixture and a white precipitate of 4-hydroxybenzoic acid was produced. The crude 4-hydroxybenzoic acid was recrystallised.
 4-hydroxybenzoic acid is soluble in different solvents but only some of these solvents are suitable for recrystallisation.
 State **two** factors that should be considered when selecting an appropriate solvent for this recrystallisation. 2

(v) In this experiment, the percentage yield of 4-hydroxybenzoic acid was 77.5%.
 Calculate the mass of ethylparaben (GFM = 166 g) required to produce 2.48 g of 4-hydroxybenzoic acid (GFM = 138 g). 2

[Turn over



10. Phenylbutazone is an anti-inflammatory drug used for the short-term treatment of pain and fever in animals.

(a) Phenylbutazone can be synthesised, in a multi-step process, starting from compound A.

Elemental microanalysis showed that compound A has a composition, by mass, of

50.0% C; 5.60% H; 44.4% O

Calculate the empirical formula of compound A.

2

(b) An infra-red spectrum for compound A is shown below.

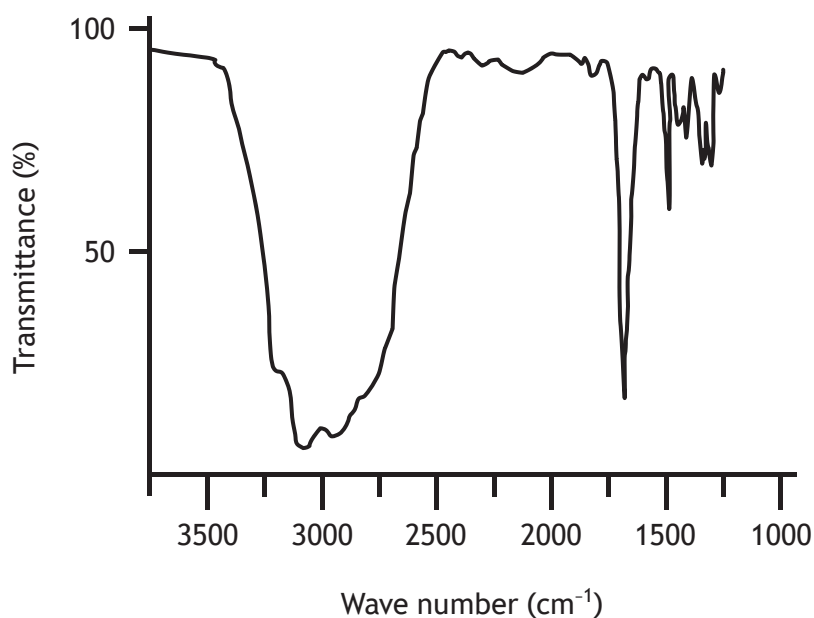

Identify the functional group responsible for the peak at 1710 cm⁻¹.

1



* X 7 1 3 7 7 0 1 2 6 *

10. (continued)

(c) The mass spectrum for compound A is shown below.

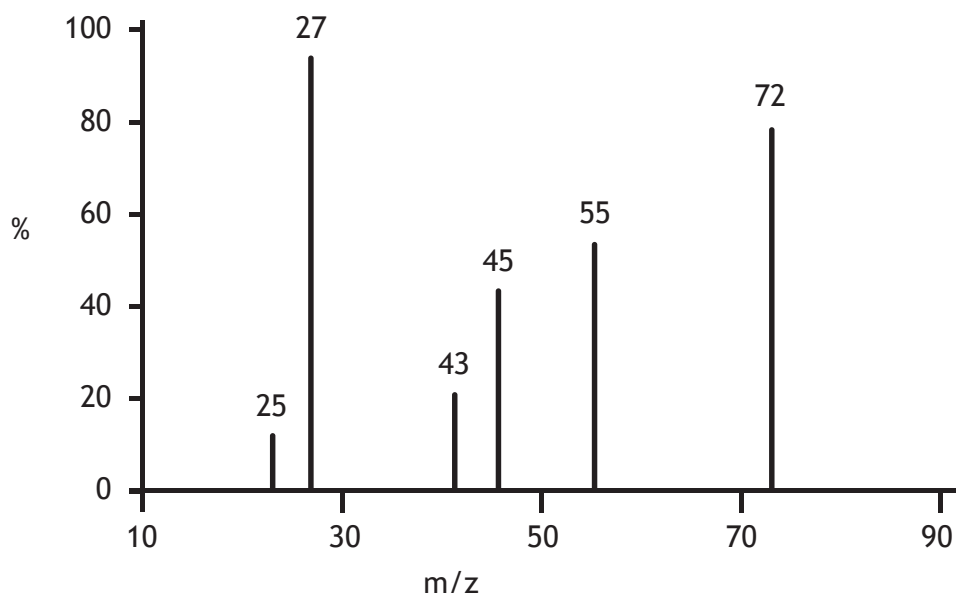

(i) Write the molecular formula for compound A.

1

(ii) Suggest a possible ion fragment that may be responsible for the peak at m/z 27.

1

(d) Considering all the evidence, draw a structural formula for compound A.

1

[END OF QUESTION PAPER]



* X 7 1 3 7 7 0 1 2 7 *

ADDITIONAL DIAGRAM FOR USE IN QUESTION 3 (a) (i)

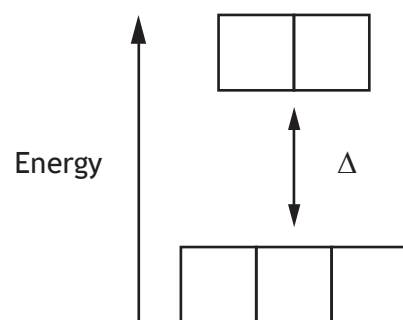

ADDITIONAL DIAGRAM FOR USE IN QUESTION 9 (b) (i)

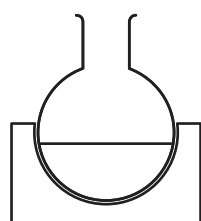

Heating mantle



* X 7 1 3 7 7 0 1 2 8 *

MARKS

DO NOT
WRITE IN
THIS
MARGIN

ADDITIONAL SPACE FOR ANSWERS AND ROUGH WORK



* X 7 1 3 7 7 0 1 2 9 *

MARKS

DO NOT
WRITE IN
THIS
MARGIN

ADDITIONAL SPACE FOR ANSWERS AND ROUGH WORK



* X 7 1 3 7 7 0 1 3 0 *

[BLANK PAGE]

DO NOT WRITE ON THIS PAGE



* X 7 1 3 7 7 0 1 3 1 *

ACKNOWLEDGEMENT

Section 2 Question 3(b) – Anna Rassadnikova/shutterstock.com

RATOCA/shutterstock.com

vladis.studio/shutterstock.com



* X 7 1 3 7 7 0 1 3 2 *