



National
Qualifications
2023 MODIFIED

X835/77/11

**Graphic Communication
Supplementary sheets**

THURSDAY, 11 MAY

1:15 PM – 3:15 PM

Supplementary sheet 1 for use with question 1 (a) to 1 (d), supplementary sheet 2 for use with question 2 (c), supplementary sheet 3 for use with question 3 (b) and 3 (c), supplementary sheet 4 for use with question 3 (d), supplementary sheet 5 for use with question 4 and supplementary sheet 6 for use with question 6.



* X 8 3 5 7 7 1 1 *



Graphic 1
company logo



Graphic 3
entrance hall poster



Graphic 2
car window sticker



Graphic 4
reusable coffee cup





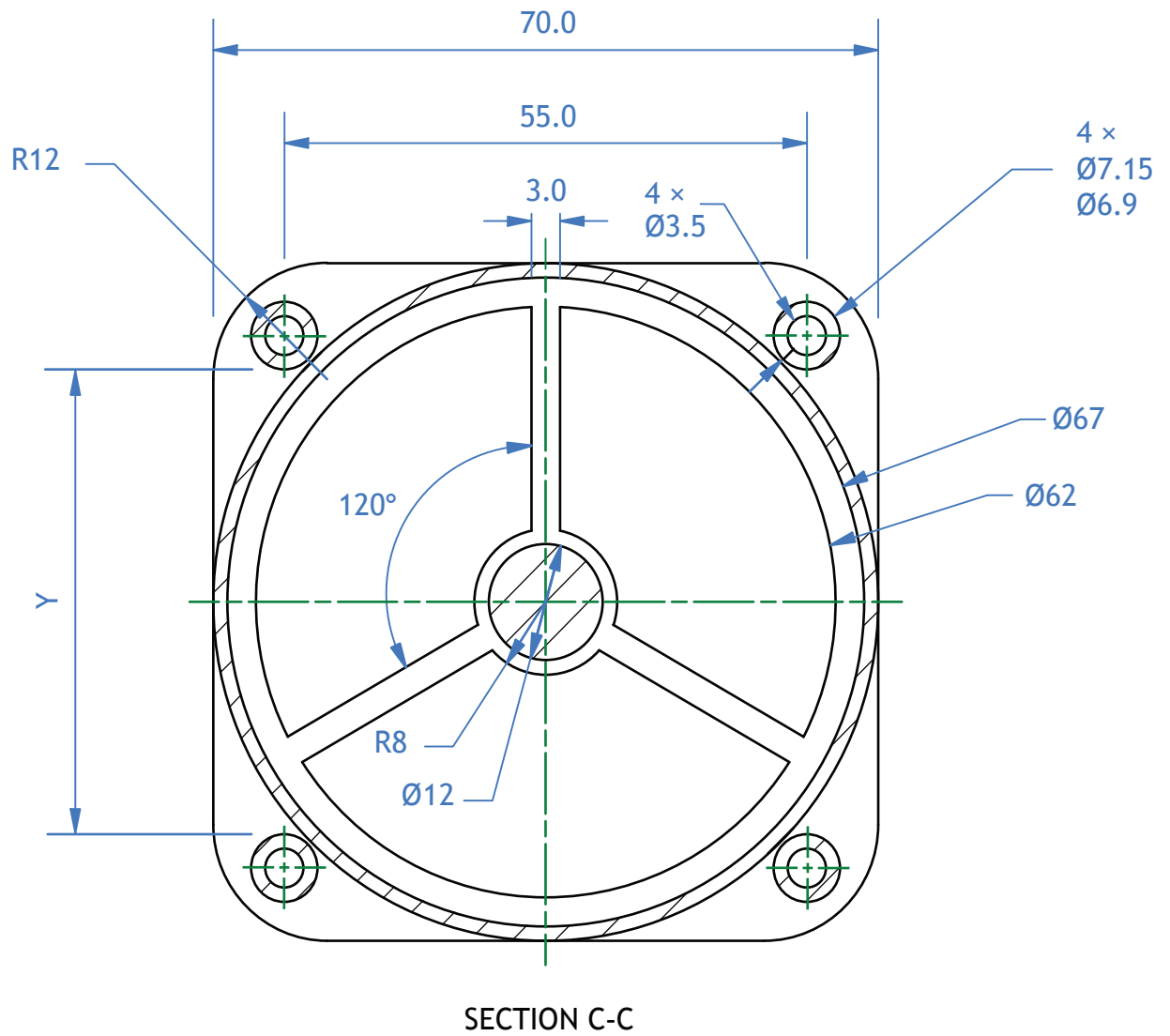
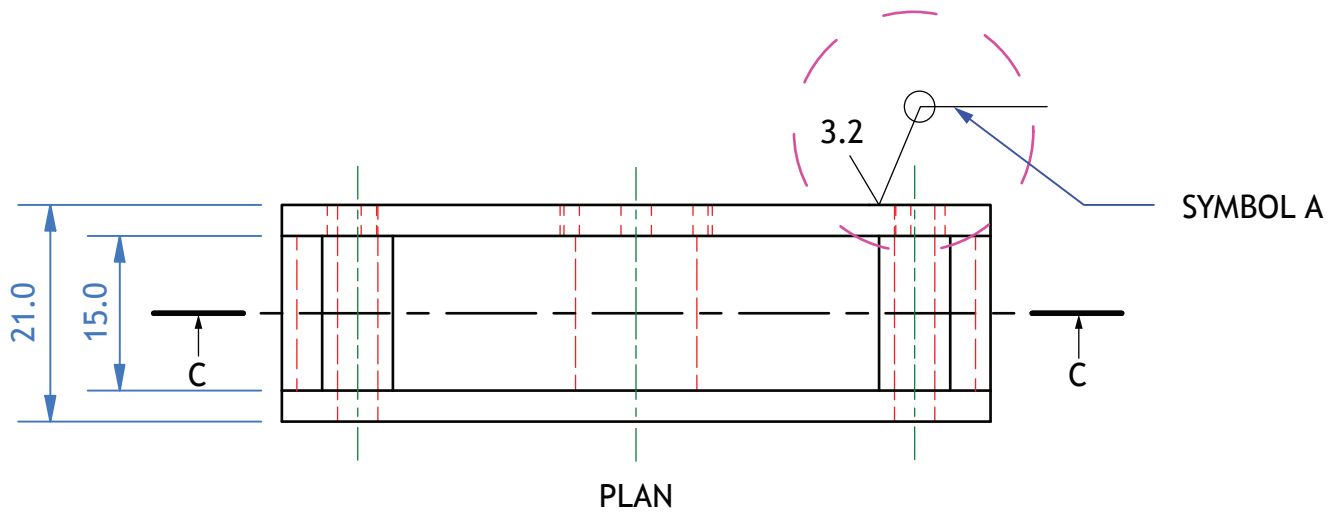

SOME CENTRE LINES HAVE BEEN
REMOVED FOR CLARITY

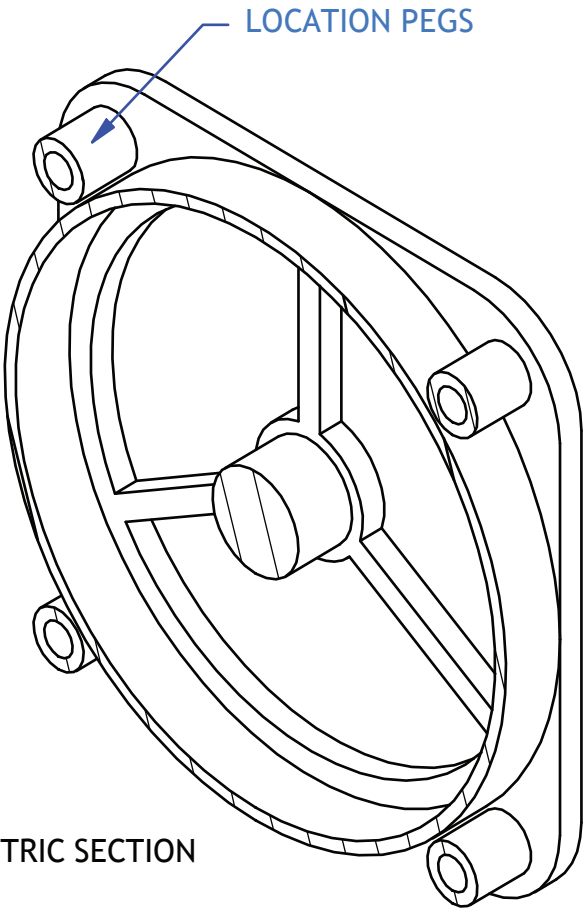

ISOMETRIC SECTION

TITLE FAN: CASING	AUTHOR: A.NON	
DRAWING NUMBER 1		
ALL DIMENSIONS IN MM		SCALE 1:1
TOLERANCE ± 0.01 UNLESS OTHERWISE STATED		DATE: 10/10/22

ISOLATED SINGLE FAN AND CENTRE PIECE

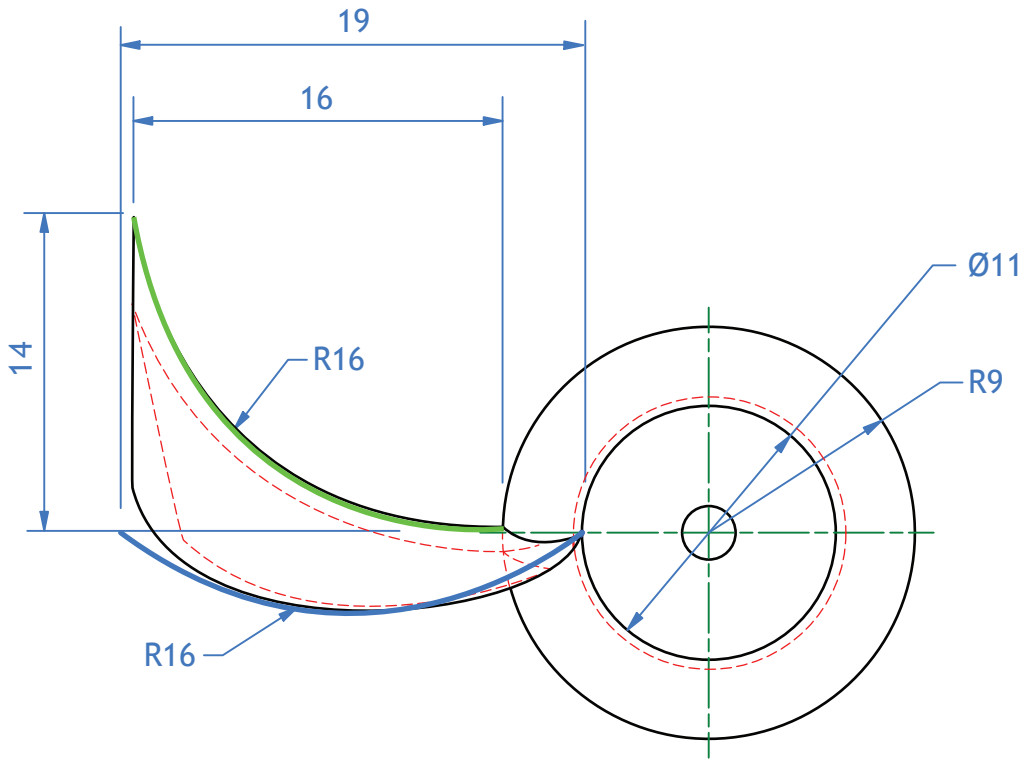

THE START POINT OF THE BOTTOM ARC IS HORIZONTALLY ALIGNED WITH THE CENTRE OF THE Ø11 CIRCLE
THE END POINT OF THE BOTTOM ARC IS IN THE POSITION SHOWN ON THE PLAN

PLAN

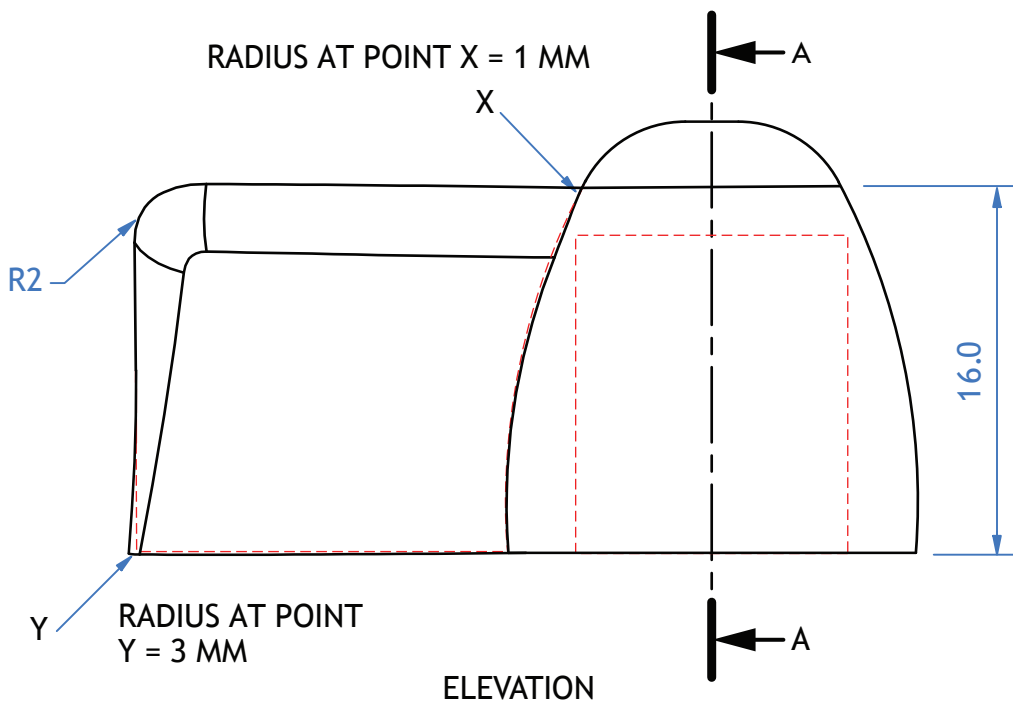

ELEVATION

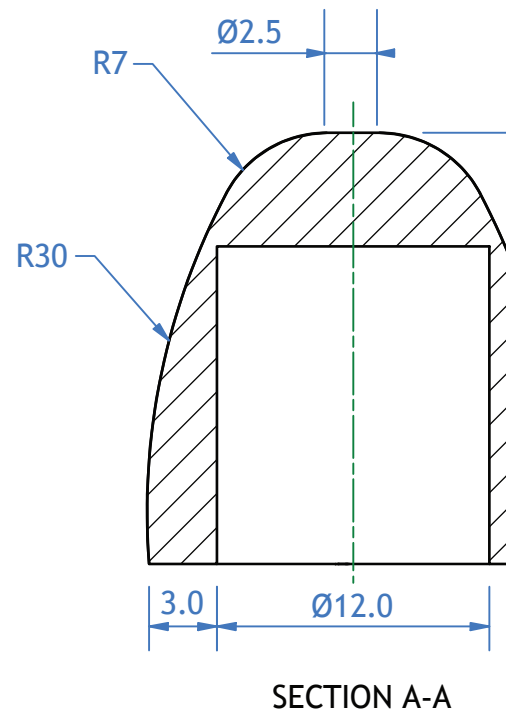

SECTION A-A

THE START AND END POINTS
OR THE TOP ARC ARE
HORIZONTALLY ALIGNED
WITH THE CENTRE OF THE
Ø11 CIRCLE.

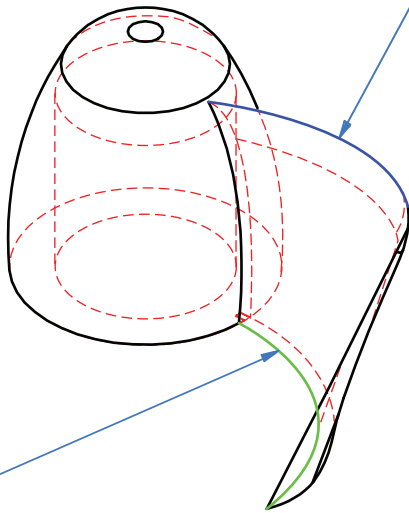

COMPLETED FAN BLADE

FAN BLADE (SURFACE MODELLED)

FAN BLADE REPEATED 12 TIMES

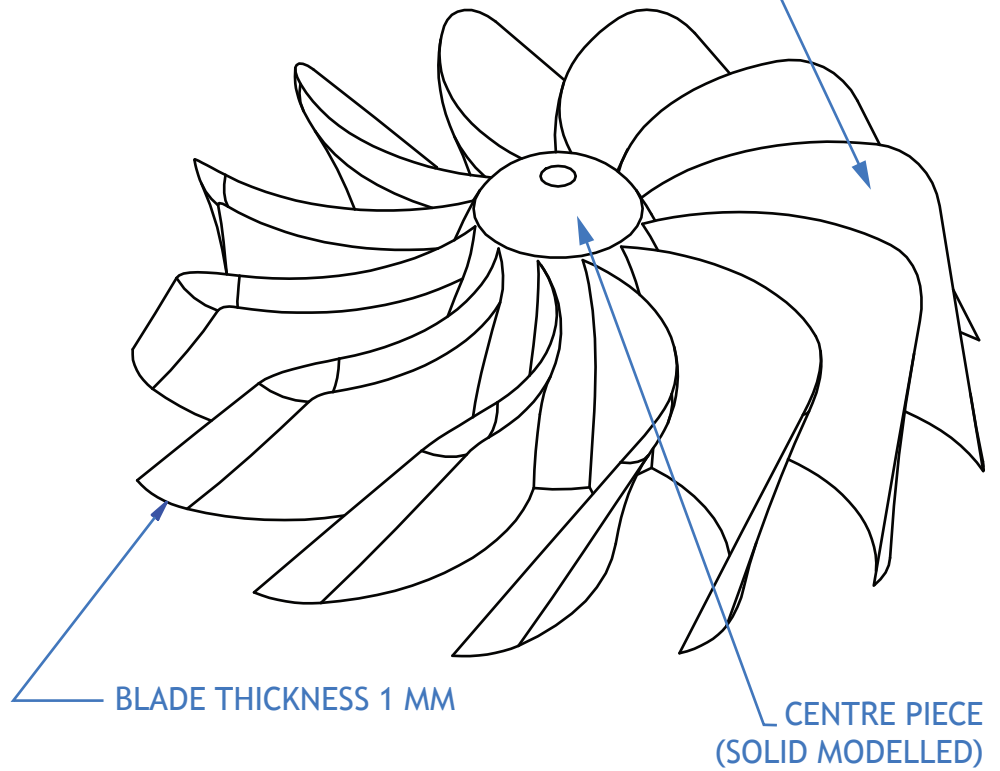

ISOMETRIC

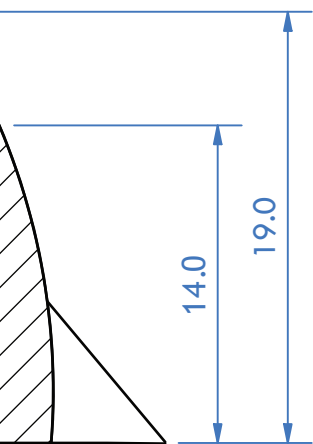

TITLE: FAN	AUTHOR: A.NON	
DRAWING NUMBER 2		
ALL DIMENSIONS IN MM		SCALE: 1:1
TOLERANCE ± 0.01 UNLESS OTHERWISE STATED		DATE: 10/10/22



Recommendations

01 / clarity

"this volume makes understanding the complex balance between light space and movement as clear as day."

A.Simpson PhD

02 / research

"a better researched volume on architecture fundamentals you will struggle to find."

A.Jones RIAS



Lorem ipsum dolor sit amet, consectetur adipiscing elit. Integer venenatis faucibus Cras placerat mattis.

E-mail : Lorem ipsu

Website : Lorem ipsu





Vol. 1

Architecture Graphics

June 2022

MK



CONTENT

2022 / SPACE

01 / use of SPACE

Basic skills in the use of space and graphics in architecture, learn skills and tricks from the pros.



02 / use of LIGHT

Basic skills in the use of light to aid decisions of space design especially in new homes and greens spaces.

Use this chapter to explore options in arrange of options in base projects and themes.

TECHNOLOGY

Use of technology in graphics to aid design decisions on projects.



WOODLEA LOCATION PLAN
SCALE 1:1250



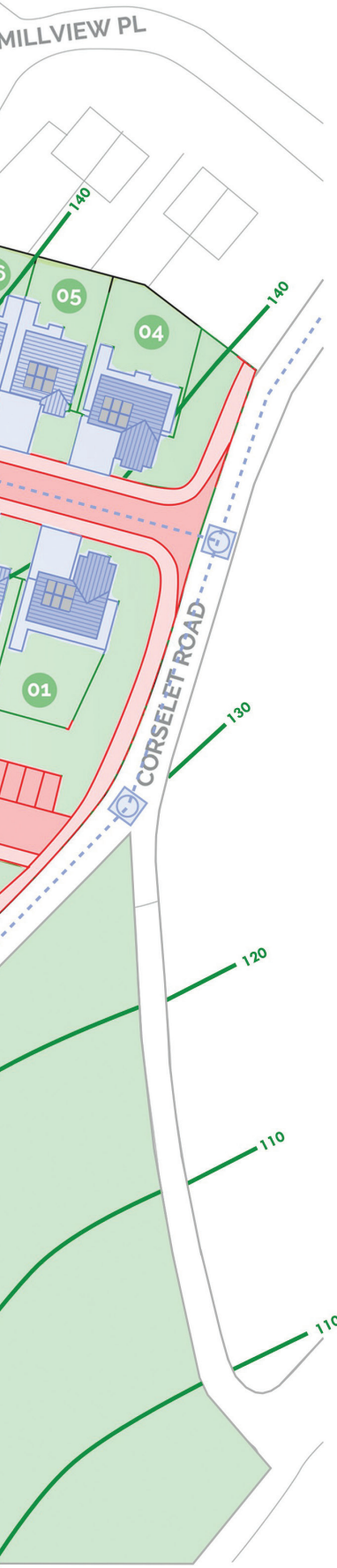

Developer Requirements

Exterior Features and Gardens:

- Turf to all front gardens.
- Rear garden choice of turf or artificial grass.
- Monobloc Driveways
- Paved areas in low cost slab
- Perimeter fencing at rear only
- Solar panning on all roofs for energy efficiency.

Common Areas:

- Artificial Grass.
- Community Garden
- Fenced around perimeter
- Plants/shrubbery to be included
- Seating made available.
- Children's play area covered in solid rubber with suitable fixtures and fittings for play.

Roads and paving:

- All roads to be laid with compacted tarmac at a depth 50 mm laid on a foundation comprising, 50 mm binder course, 200 mm sub-base and 150 mm sub-grade.
- All paving to be laid using compacted asphalt at a depth of 50 mm.
- Standard concrete kerbs to be laid between tarmac and pavements.

Plot Sizes:



The Oak
3 Bed Detached
96.4m² / 1038ft²



The Hazel
3 Bed Detached
105.6m² / 1137ft²



The Birch
4 Bed Detached
129.4m² / 1393ft²



The Maple
4 Bed Detached
115.1m² / 1240ft²



The Ash
3 Bed Semi-Detached
95.5m² / 1028ft²



The Alder
3 Bed Detached
102.6m² / 1104ft²



The Willow
4 Bed Detached
140.3m² / 1510ft²



The Juniper
4 Bed Detached
134.5m² / 1449ft²

[BLANK PAGE]

DO NOT WRITE ON THIS PAGE

[BLANK PAGE]

DO NOT WRITE ON THIS PAGE

[BLANK PAGE]

DO NOT WRITE ON THIS PAGE

Acknowledgement of copyright

Supplementary sheet 1 kstudija/shutterstock.com

Supplementary sheet 2 korisbo/shutterstock.com

Supplementary sheet 4 TomTomTom CreativeHub/shutterstock.com

Supplementary sheet 6 Woodlea location plan is reproduced by kind permission of Briar Homes.