



National
Qualifications
2024

X835/77/11

**Graphic Communication
Supplementary sheets**

THURSDAY, 16 MAY

9:00 AM – 11:30 AM

Supplementary sheet 1 for use with question 2 (d), supplementary sheet 2 for use with question 4 (a), supplementary sheet 3 for use with question 4 (b), supplementary sheet 4 for use with question 4 (c), supplementary sheet 4a for use with question 5 (a) and supplementary sheet 4b for use with question 5 (a).



* X 8 3 5 7 7 1 1 *

Camera Ready Copy: Front of Business Card

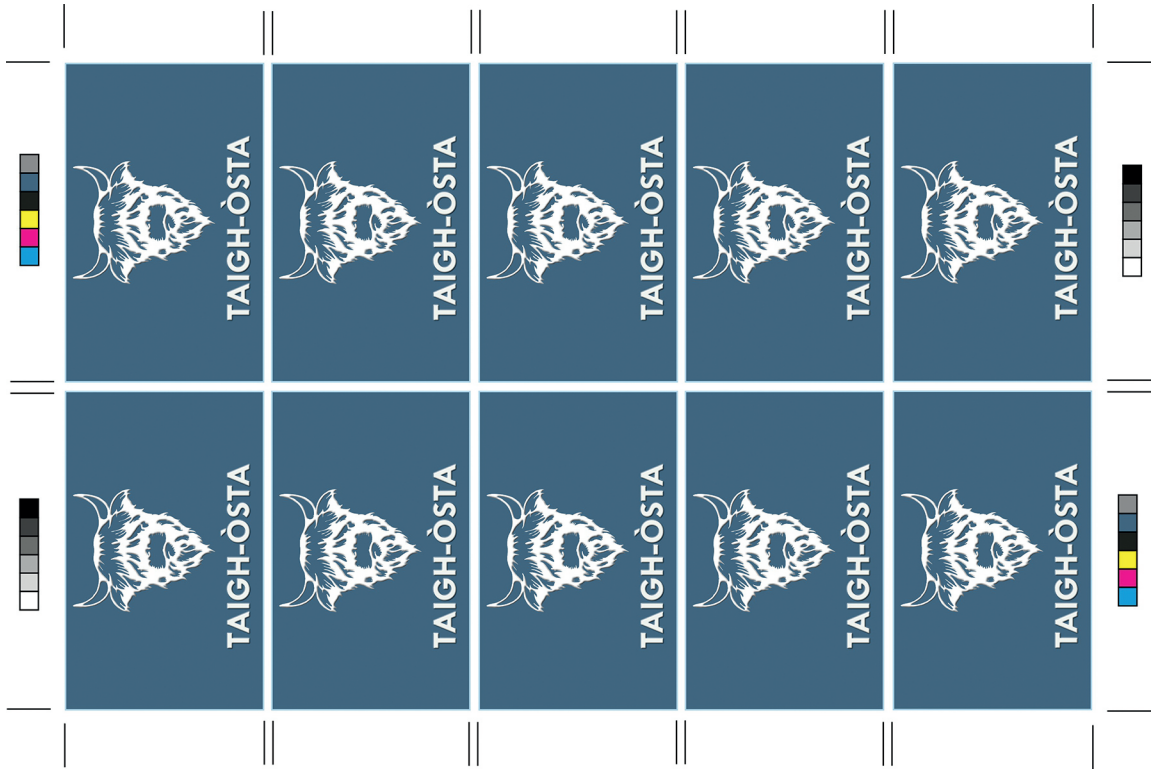

Camera Ready Copy: Back of Business Card



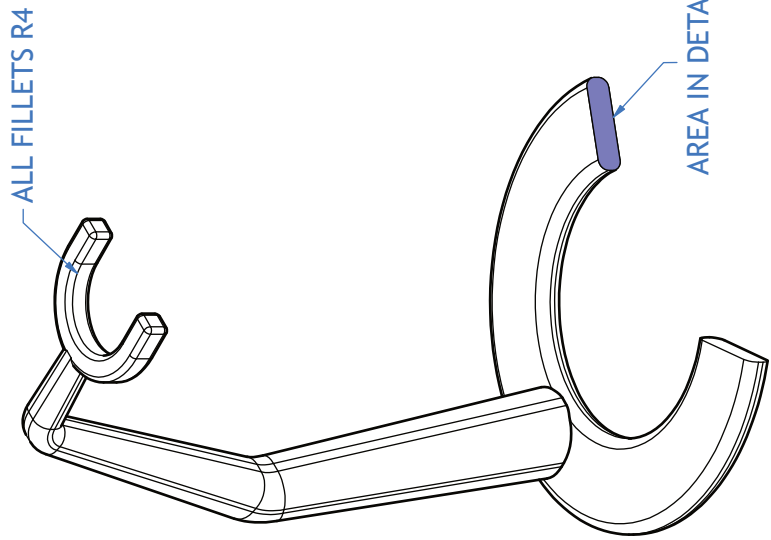
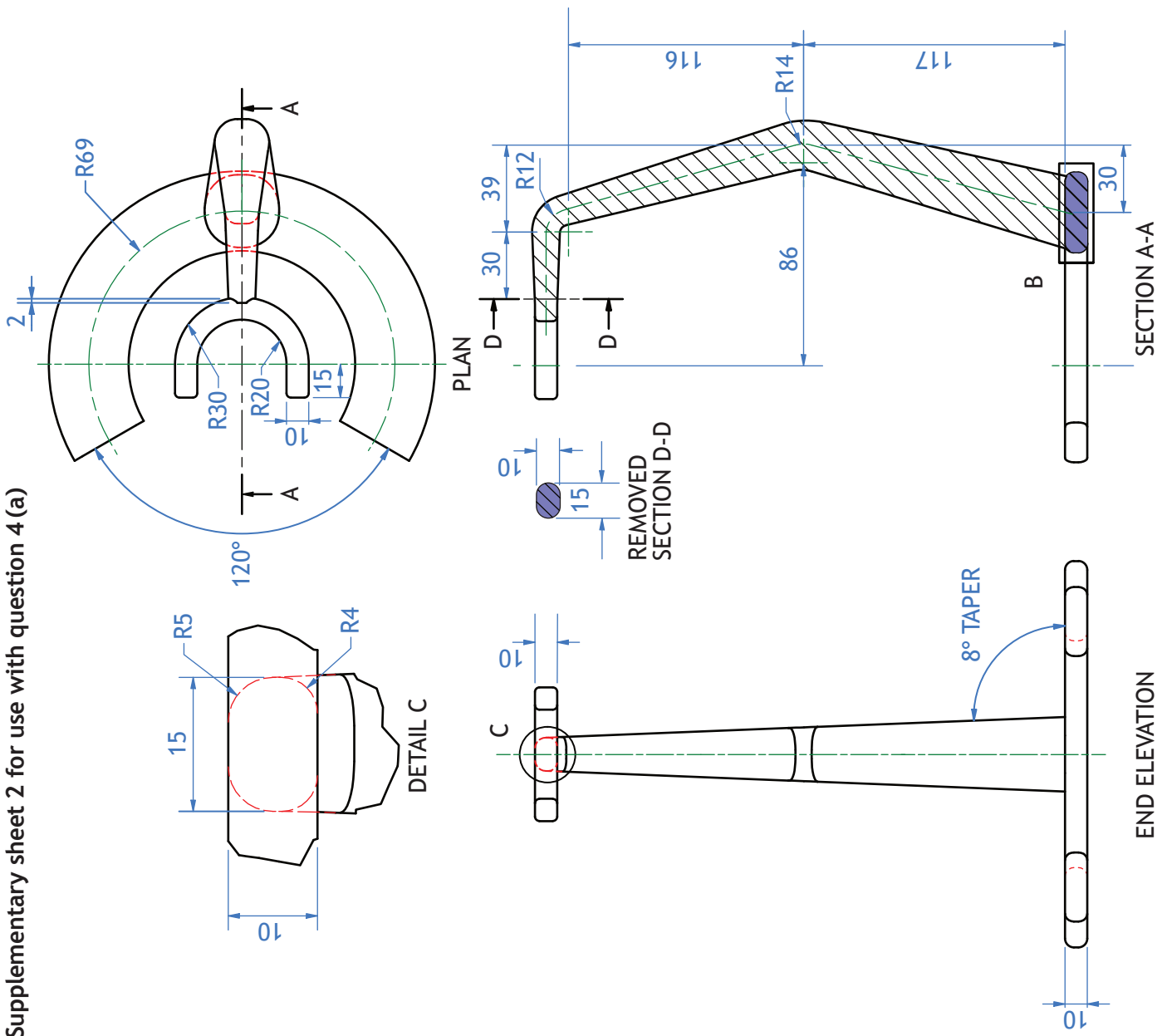

PICTORIAL

SOME CENTRE LINES AND HIDDEN DETAIL HAVE BEEN REMOVED FOR CLARITY

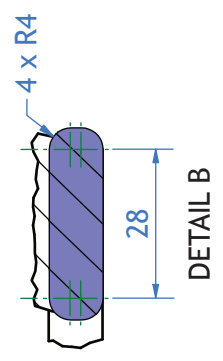

TITLE: STAND	AUTHOR: A.NON	
DRAWING NUMBER 1		
ALL DIMENSIONS IN MM	SCALE: NOT TO SCALE	
TOLERANCE ±0.01 UNLESS OTHERWISE STATED	DATE: 10/10/22	

Supplementary sheet 3 for use with question 4 (b)

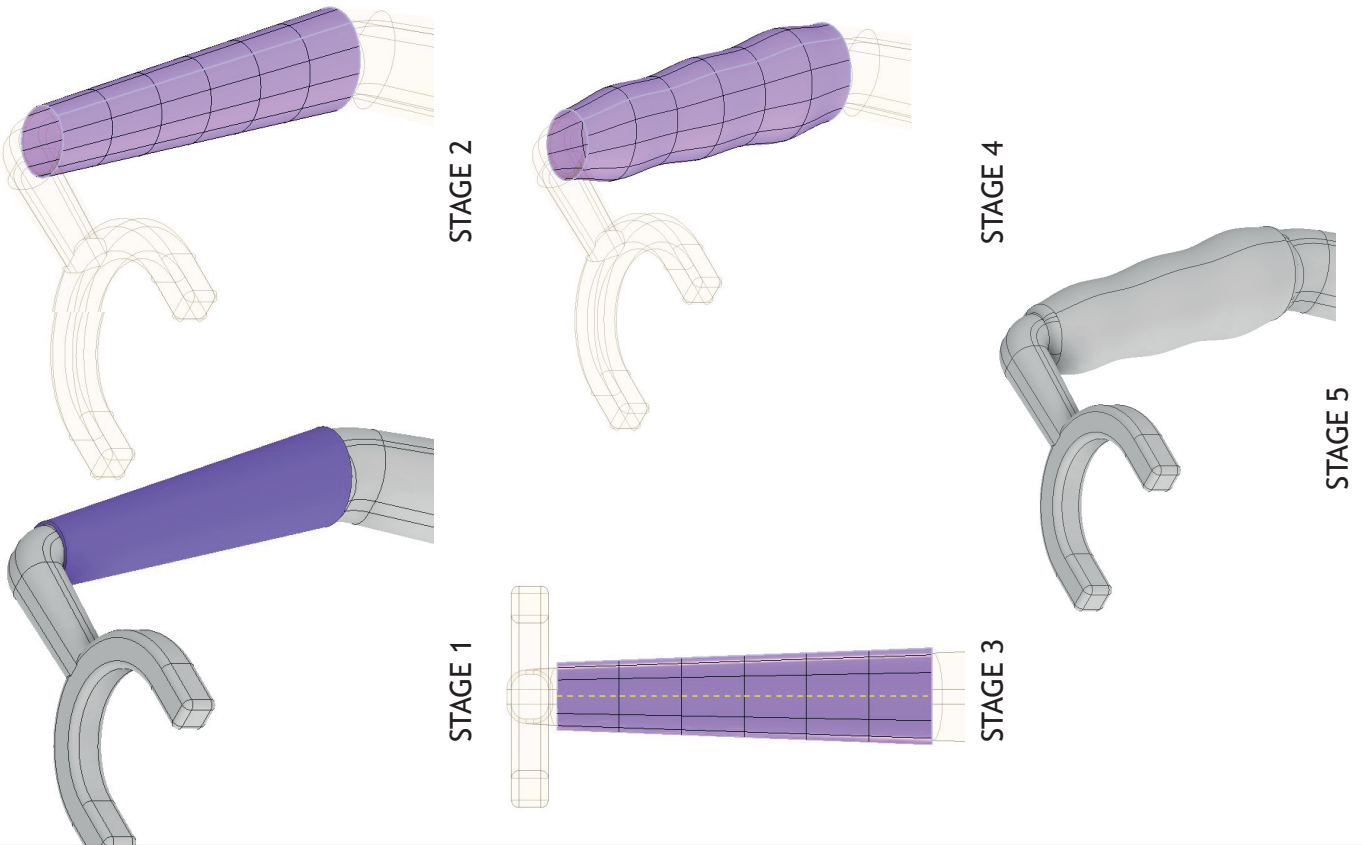

Supplementary sheet 4 for use with question 4 (c)

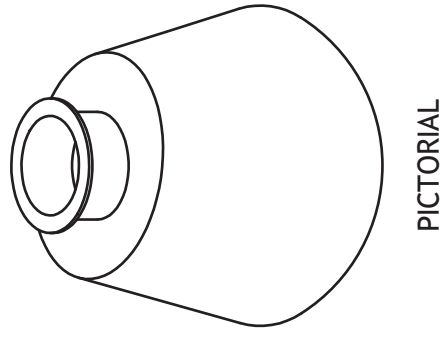
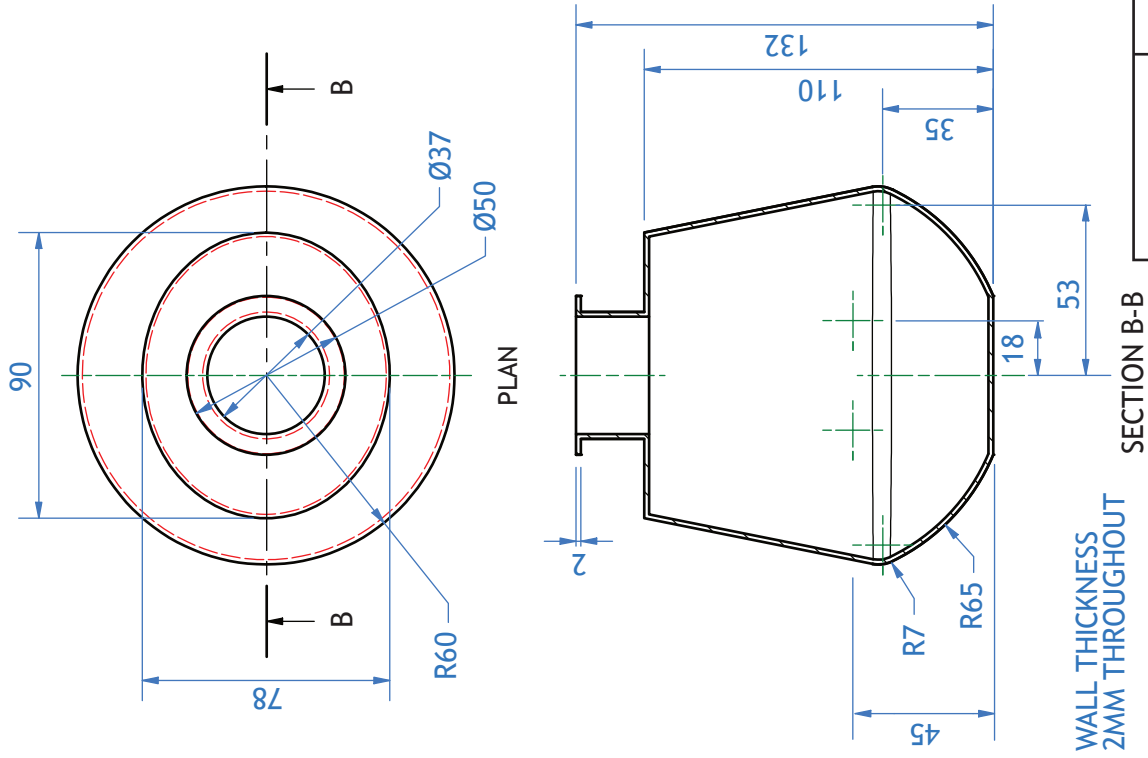

PICTORIAL

SOME HIDDEN DETAIL LINES HAVE BEEN REMOVED FOR CLARITY

WALL THICKNESS 2MM THROUGHOUT

TITLE: BEAKER	AUTHOR: A.NON	
DRAWING NUMBER 2		SCALE: NOT TO SCALE
ALL DIMENSIONS IN MM		DATE: 10/10/22
TOLERANCE ± 0.01 UNLESS OTHERWISE STATED		

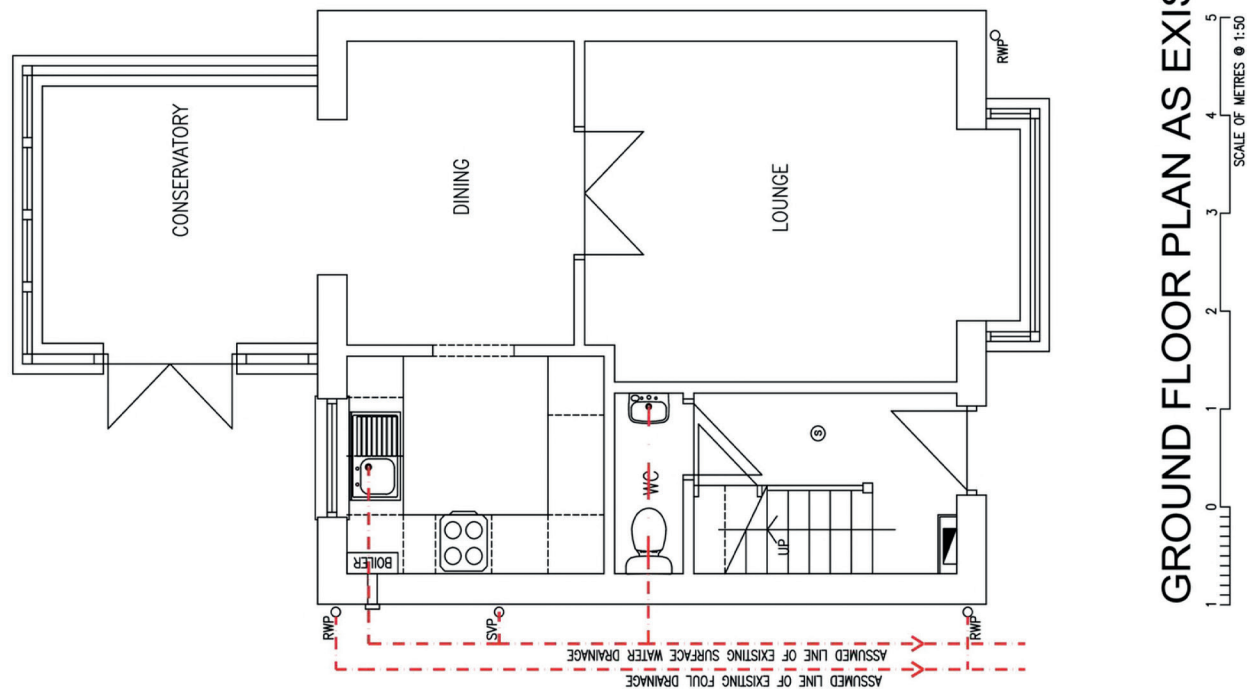

GROUND FLOOR PLAN AS EXISTING

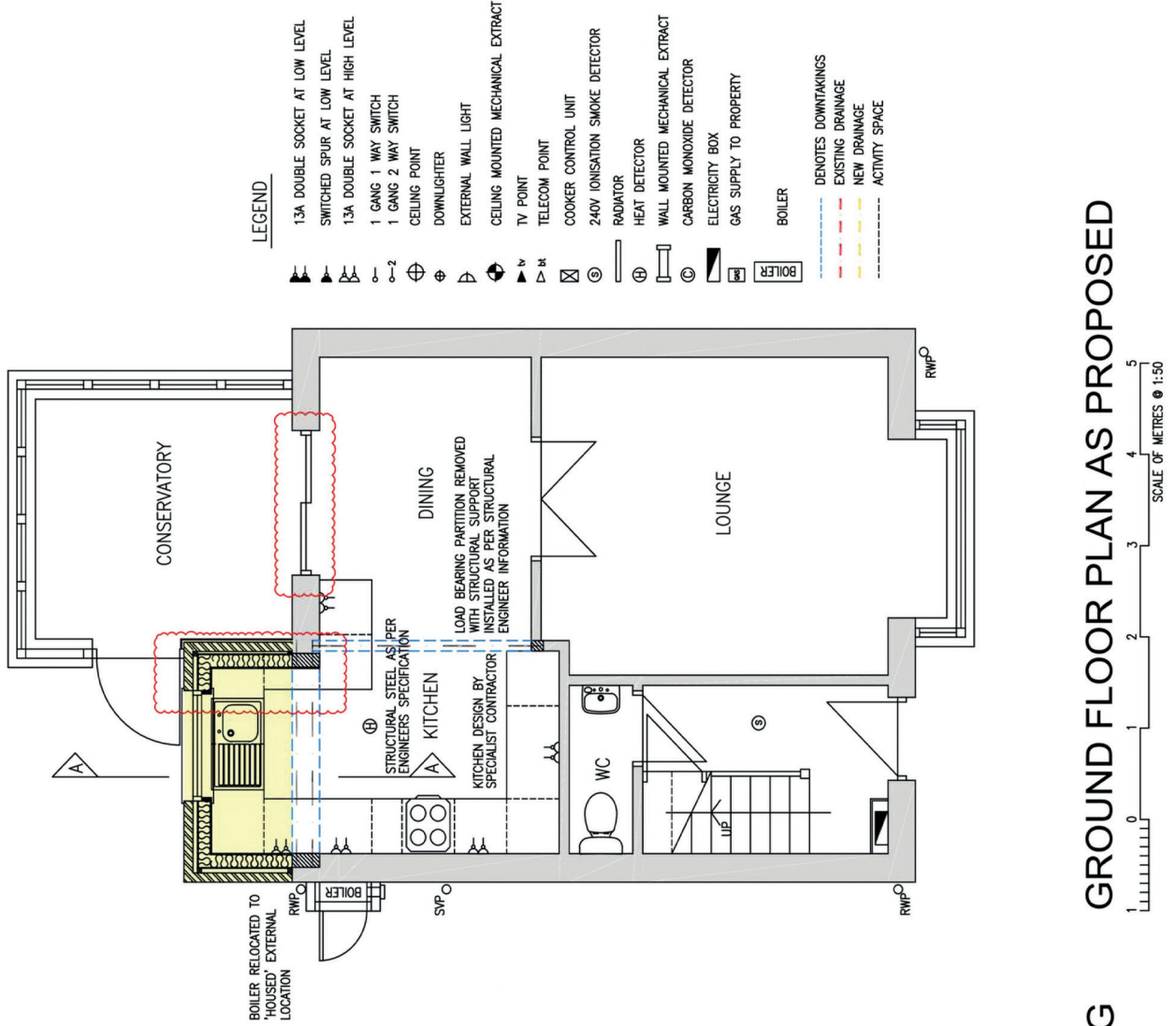

GROUND FLOOR PLAN AS PROPOSED

LEGEND

- 13A DOUBLE SOCKET AT LOW LEVEL
 - SWITCHED SPUR AT LOW LEVEL
 - 13A DOUBLE SOCKET AT HIGH LEVEL
 - 1 GANG 1 WAY SWITCH
 - 1 GANG 2 WAY SWITCH
 - CEILING POINT
 - DOWNLIGHTER
 - EXTERNAL WALL LIGHT
 - CEILING MOUNTED MECHANICAL EXTRACT
 - TV POINT
 - TELECOM POINT
 - COOKER CONTROL UNIT
 - 240V IONISATION SMOKE DETECTOR
 - RADIATOR
 - HEAT DETECTOR
 - WALL MOUNTED MECHANICAL EXTRACT
 - CARBON MONOXIDE DETECTOR
 - ELECTRICITY BOX
 - GAS SUPPLY TO PROPERTY
 - BOILER
- DENOTES DOWNTAKINGS
- EXISTING DRAINAGE
 - NEW DRAINAGE
 - ACTIVITY SPACE

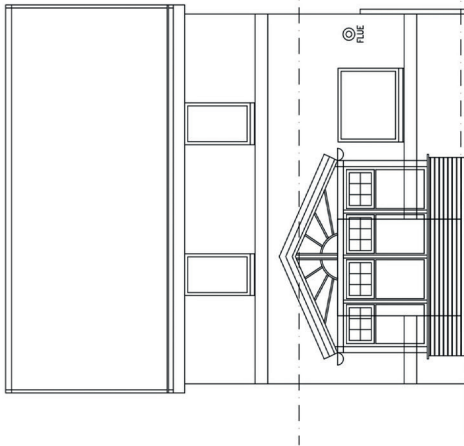

REAR ELEVATION AS EXISTING

SCALE OF METRES @ 1:50

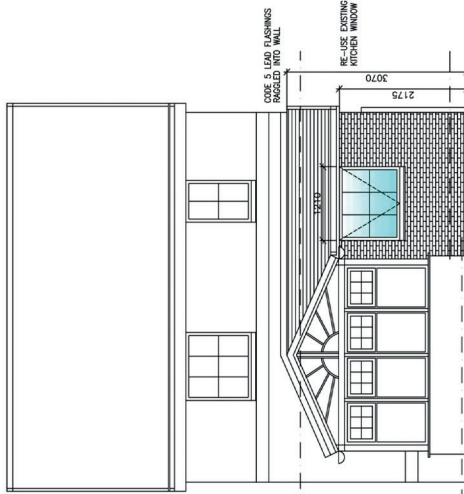

REAR ELEVATION AS PROPOSED

SCALE OF METRES @ 1:50

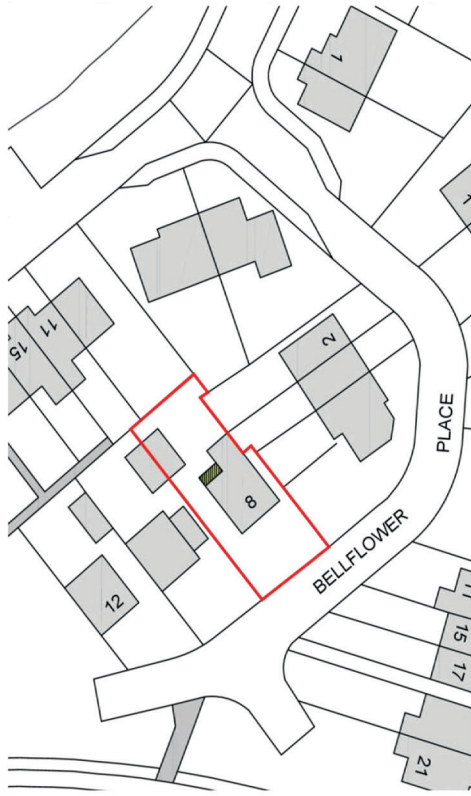

LOCATION PLAN AS PROPOSED

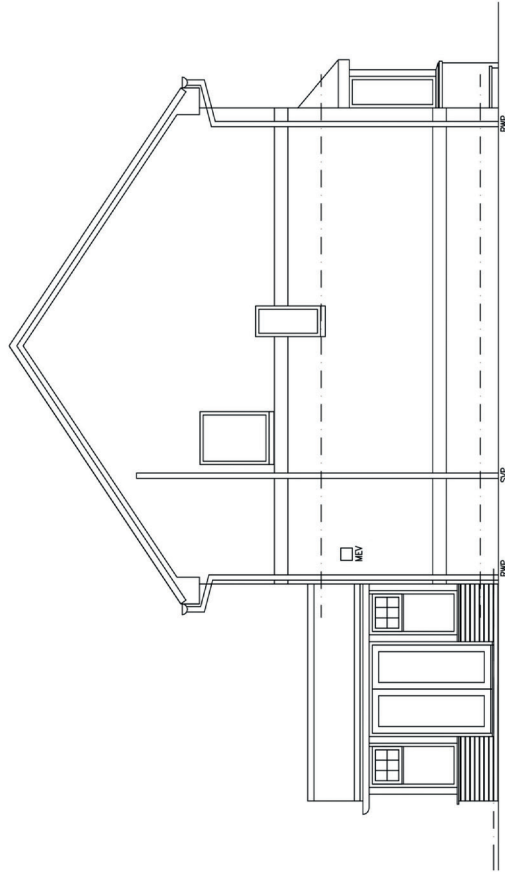

SIDE ELEVATION AS EXISTING

SCALE OF METRES @ 1:50

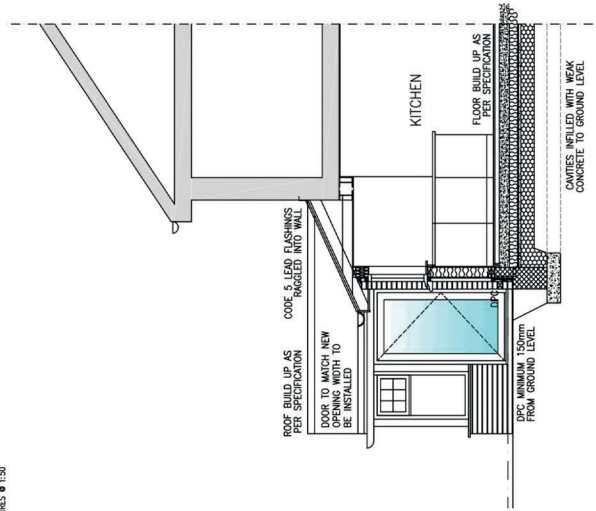

SECTION A-A AS PROPOSED

SCALE OF METRES @ 1:50

[BLANK PAGE]

DO NOT WRITE ON THIS PAGE

[BLANK PAGE]

DO NOT WRITE ON THIS PAGE

Acknowledgement of copyright

Supplementary sheet 1 for use with question 2 (d): Robcartorres/shutterstock.com