



National  
Qualifications  
2018

**X747/77/11**

**Mathematics**

THURSDAY, 3 MAY  
9:00 AM – 12:00 NOON

---

**Total marks — 100**

Attempt ALL questions.

**You may use a calculator.**

Full credit will be given only to solutions which contain appropriate working.

State the units for your answer where appropriate.

Answers obtained by readings from scale drawings will not receive any credit.

Write your answers clearly in the answer booklet provided. In the answer booklet you must clearly identify the question number you are attempting.

Use **blue** or **black** ink.

Before leaving the examination room you must give your answer booklet to the Invigilator; if you do not, you may lose all the marks for this paper.



\* X 7 4 7 7 7 1 1 \*

## FORMULAE LIST

Standard derivatives	
$f(x)$	$f'(x)$
$\sin^{-1} x$	$\frac{1}{\sqrt{1-x^2}}$
$\cos^{-1} x$	$-\frac{1}{\sqrt{1-x^2}}$
$\tan^{-1} x$	$\frac{1}{1+x^2}$
$\tan x$	$\sec^2 x$
$\cot x$	$-\operatorname{cosec}^2 x$
$\sec x$	$\sec x \tan x$
$\operatorname{cosec} x$	$-\operatorname{cosec} x \cot x$
$\ln x$	$\frac{1}{x}$
$e^x$	$e^x$

Standard integrals	
$f(x)$	$\int f(x) dx$
$\sec^2(ax)$	$\frac{1}{a} \tan(ax) + c$
$\frac{1}{\sqrt{a^2-x^2}}$	$\sin^{-1}\left(\frac{x}{a}\right) + c$
$\frac{1}{a^2+x^2}$	$\frac{1}{a} \tan^{-1}\left(\frac{x}{a}\right) + c$
$\frac{1}{x}$	$\ln x  + c$
$e^{ax}$	$\frac{1}{a} e^{ax} + c$

### Summations

(Arithmetic series)  $S_n = \frac{1}{2}n[2a + (n-1)d]$

(Geometric series)  $S_n = \frac{a(1-r^n)}{1-r}, r \neq 1$

$$\sum_{r=1}^n r = \frac{n(n+1)}{2}, \quad \sum_{r=1}^n r^2 = \frac{n(n+1)(2n+1)}{6}, \quad \sum_{r=1}^n r^3 = \frac{n^2(n+1)^2}{4}$$

### Binomial theorem

$$(a+b)^n = \sum_{r=0}^n \binom{n}{r} a^{n-r} b^r \quad \text{where} \quad \binom{n}{r} = {}^n C_r = \frac{n!}{r!(n-r)!}$$

### Maclaurin expansion

$$f(x) = f(0) + f'(0)x + \frac{f''(0)x^2}{2!} + \frac{f'''(0)x^3}{3!} + \frac{f^{iv}(0)x^4}{4!} + \dots$$

## FORMULAE LIST (continued)

### De Moivre's theorem

$$[r(\cos \theta + i \sin \theta)]^n = r^n (\cos n\theta + i \sin n\theta)$$

### Vector product

$$\mathbf{a} \times \mathbf{b} = |\mathbf{a}||\mathbf{b}|\sin \theta \hat{\mathbf{n}} = \begin{vmatrix} \mathbf{i} & \mathbf{j} & \mathbf{k} \\ a_1 & a_2 & a_3 \\ b_1 & b_2 & b_3 \end{vmatrix} = \mathbf{i} \begin{vmatrix} a_2 & a_3 \\ b_2 & b_3 \end{vmatrix} - \mathbf{j} \begin{vmatrix} a_1 & a_3 \\ b_1 & b_3 \end{vmatrix} + \mathbf{k} \begin{vmatrix} a_1 & a_2 \\ b_1 & b_2 \end{vmatrix}$$

### Matrix transformation

Anti-clockwise rotation through an angle,  $\theta$ , about the origin,  $\begin{pmatrix} \cos \theta & -\sin \theta \\ \sin \theta & \cos \theta \end{pmatrix}$

[Turn over

**Total marks – 100**  
**Attempt ALL questions**

1. (a) Given  $f(x) = \sin^{-1} 3x$ , find  $f'(x)$ . 2
- (b) Differentiate  $y = \frac{e^{5x}}{7x+1}$ . 2
- (c) For  $y \cos x + y^2 = 6x$ , use implicit differentiation to find  $\frac{dy}{dx}$ . 4
2. Use partial fractions to find  $\int \frac{3x-7}{x^2-2x-15} dx$ . 4
3. (a) Write down and simplify the general term in the binomial expansion of  $\left(2x + \frac{5}{x^2}\right)^9$ . 3
- (b) Hence, or otherwise, find the term independent of  $x$ . 2
4. Given that  $z_1 = 2 + 3i$  and  $z_2 = p - 6i$ ,  $p \in \mathbb{R}$ , find:
- (a)  $z_1 \bar{z}_2$ ; 2
- (b) the value of  $p$  such that  $z_1 \bar{z}_2$  is a real number. 1
5. Use the Euclidean algorithm to find integers  $a$  and  $b$  such that  $306a + 119b = 17$ . 4

6. On a suitable domain, a curve is defined parametrically by  $x = t^2 + 1$  and  $y = \ln(3t + 2)$ .

Find the equation of the tangent to the curve where  $t = -\frac{1}{3}$ .

5

7. Matrices  $C$  and  $D$  are given by:

$$C = \begin{pmatrix} -2 & 1 & 2 \\ 1 & -1 & 0 \\ 1 & 0 & -1 \end{pmatrix} \quad \text{and} \quad D = \begin{pmatrix} 1 & 1 & 2 \\ k+3 & 0 & 2 \\ 1 & 1 & 1 \end{pmatrix}, \text{ where } k \in \mathbb{R}.$$

- (a) Obtain  $2C' - D$  where  $C'$  is the transpose of  $C$ . 2
- (b) (i) Find and simplify an expression for the determinant of  $D$ . 2
- (ii) State the value of  $k$  such that  $D^{-1}$  does not exist. 1

8. Using the substitution  $u = \sin \theta$ , or otherwise, evaluate

$$\int_{\frac{\pi}{6}}^{\frac{\pi}{2}} 2 \sin^4 \theta \cos \theta \, d\theta.$$

4

9. Prove directly that:

- (a) the sum of any three consecutive integers is divisible by 3; 2
- (b) any odd integer can be expressed as the sum of two consecutive integers. 1

[Turn over

10. Given  $z = x + iy$ , sketch the locus in the complex plane given by  $|z| = |z - 2 + 2i|$ . 3

11. (a) Obtain the matrix,  $A$ , associated with an anticlockwise rotation of  $\frac{\pi}{3}$  radians about the origin. 1

(b) Find the matrix,  $B$ , associated with a reflection in the  $x$ -axis. 1

(c) Hence obtain the matrix,  $P$ , associated with an anticlockwise rotation of  $\frac{\pi}{3}$  radians about the origin followed by reflection in the  $x$ -axis, expressing your answer using exact values. 2

(d) Explain why matrix  $P$  is not associated with rotation about the origin. 1

12. Prove by induction that, for all positive integers  $n$ ,

$$\sum_{r=1}^n 3^{r-1} = \frac{1}{2}(3^n - 1). \quad 5$$

13. An engineer has designed a lifting device. The handle turns a screw which shortens the horizontal length and increases the vertical height.

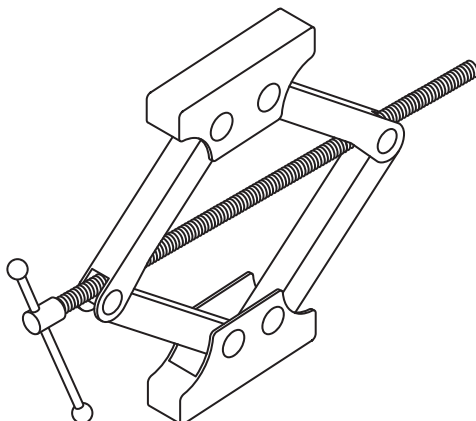

The device is modelled by a rhombus, with each side 25 cm.

The horizontal length is  $x$  cm, and the vertical height is  $h$  cm as shown.

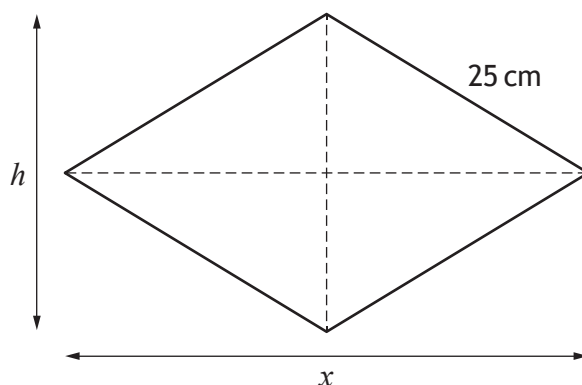

- (a) Show that  $h = \sqrt{2500 - x^2}$ . 1
- (b) The horizontal length decreases at a rate of 0.3 cm per second as the handle is turned. 5  
Find the rate of change of the vertical height when  $x = 30$ .

[Turn over

14. A geometric sequence has first term 80 and common ratio  $\frac{1}{3}$ .

(a) For this sequence, calculate:

(i) the 7<sup>th</sup> term; 2

(ii) the sum to infinity of the associated geometric series. 2

The first term of this geometric sequence is equal to the first term of an arithmetic sequence.

The sum of the first five terms of this arithmetic sequence is 240.

(b) (i) Find the common difference of this sequence. 2

(ii) Write down and simplify an expression for the  $n$ th term. 1

Let  $S_n$  represent the sum of the first  $n$  terms of this arithmetic sequence.

(c) Find the values of  $n$  for which  $S_n = 144$ . 3

15. (a) Use integration by parts to find  $\int x \sin 3x \, dx$ . 3

(b) Hence find the particular solution of

$$\frac{dy}{dx} - \frac{2}{x}y = x^3 \sin 3x, \quad x \neq 0$$

given that  $x = \pi$  when  $y = 0$ .

Express your answer in the form  $y = f(x)$ . 7

16. Planes  $\pi_1$ ,  $\pi_2$  and  $\pi_3$  have equations:

$$\pi_1: \quad x - 2y + z = -4$$

$$\pi_2: \quad 3x - 5y - 2z = 1$$

$$\pi_3: \quad -7x + 11y + az = -11$$

where  $a \in \mathbb{R}$ .

(a) Use Gaussian elimination to find the value of  $a$  such that the intersection of the planes  $\pi_1$ ,  $\pi_2$  and  $\pi_3$  is a line. 4

(b) Find the equation of the line of intersection of the planes when  $a$  takes this value. 2

The plane  $\pi_4$  has equation  $-9x + 15y + 6z = 20$ .

(c) Find the acute angle between  $\pi_1$  and  $\pi_4$ . 3

(d) Describe the geometrical relationship between  $\pi_2$  and  $\pi_4$ .  
Justify your answer. 1

17. (a) Given  $f(x) = e^{2x}$ , obtain the Maclaurin expansion for  $f(x)$  up to, and including, the term in  $x^3$ . 2

(b) On a suitable domain, let  $g(x) = \tan x$ .

(i) Show that the third derivative of  $g(x)$  is given by  
 $g'''(x) = 2\sec^4 x + 4\tan^2 x \sec^2 x$ . 3

(ii) Hence obtain the Maclaurin expansion for  $g(x)$  up to and including the term in  $x^3$ . 2

(c) Hence, or otherwise, obtain the Maclaurin expansion for  $e^{2x} \tan x$  up to, and including, the term in  $x^3$ . 2

(d) Write down the first three non-zero terms in the Maclaurin expansion for  $2e^{2x} \tan x + e^{2x} \sec^2 x$ . 1

[END OF QUESTION PAPER]

[BLANK PAGE]

DO NOT WRITE ON THIS PAGE

[BLANK PAGE]

DO NOT WRITE ON THIS PAGE

[BLANK PAGE]

DO NOT WRITE ON THIS PAGE