

FOR OFFICIAL USE



--	--	--	--	--	--

National  
Qualifications  
2017

Mark

--

**X757/77/01**

**Physics**

WEDNESDAY, 17 MAY

9:00 AM – 11:30 AM



\* X 7 5 7 7 7 0 1 \*

Fill in these boxes and read what is printed below.

Full name of centre

--

Town

--

Forename(s)

--

Surname

--

Number of seat

--

Date of birth

Day

--	--

Month

--	--

Year

--	--

Scottish candidate number

--	--	--	--	--	--	--	--	--	--

**Total marks — 140**

Attempt ALL questions.

Reference may be made to the Physics Relationship Sheet X757/77/11 and the Data Sheet on *Page 02*.

Write your answers clearly in the spaces provided in this booklet. Additional space for answers and rough work is provided at the end of this booklet. If you use this space you must clearly identify the question number you are attempting. Any rough work must be written in this booklet. You should score through your rough work when you have written your final copy.

Care should be taken to give an appropriate number of significant figures in the final answers to calculations.

Use **blue** or **black** ink.

Before leaving the examination room you must give this booklet to the Invigilator; if you do not, you may lose all the marks for this paper.



\* X 7 5 7 7 7 0 1 0 1 \*

## DATA SHEET

### COMMON PHYSICAL QUANTITIES

Quantity	Symbol	Value	Quantity	Symbol	Value
Gravitational acceleration on Earth	$g$	$9.8 \text{ m s}^{-2}$	Mass of electron	$m_e$	$9.11 \times 10^{-31} \text{ kg}$
Radius of Earth	$R_E$	$6.4 \times 10^6 \text{ m}$	Charge on electron	$e$	$-1.60 \times 10^{-19} \text{ C}$
Mass of Earth	$M_E$	$6.0 \times 10^{24} \text{ kg}$	Mass of neutron	$m_n$	$1.675 \times 10^{-27} \text{ kg}$
Mass of Moon	$M_M$	$7.3 \times 10^{22} \text{ kg}$	Mass of proton	$m_p$	$1.673 \times 10^{-27} \text{ kg}$
Radius of Moon	$R_M$	$1.7 \times 10^6 \text{ m}$	Mass of alpha particle	$m_\alpha$	$6.645 \times 10^{-27} \text{ kg}$
Mean Radius of Moon Orbit		$3.84 \times 10^8 \text{ m}$	Charge on alpha particle		$3.20 \times 10^{-19} \text{ C}$
Solar radius		$6.955 \times 10^8 \text{ m}$	Planck's constant	$h$	$6.63 \times 10^{-34} \text{ J s}$
Mass of Sun		$2.0 \times 10^{30} \text{ kg}$	Permittivity of free space	$\epsilon_0$	$8.85 \times 10^{-12} \text{ F m}^{-1}$
1 AU		$1.5 \times 10^{11} \text{ m}$	Permeability of free space	$\mu_0$	$4\pi \times 10^{-7} \text{ H m}^{-1}$
Stefan-Boltzmann constant	$\sigma$	$5.67 \times 10^{-8} \text{ W m}^{-2} \text{ K}^{-4}$	Speed of light in vacuum	$c$	$3.00 \times 10^8 \text{ m s}^{-1}$
Universal constant of gravitation	$G$	$6.67 \times 10^{-11} \text{ m}^3 \text{ kg}^{-1} \text{ s}^{-2}$	Speed of sound in air	$v$	$3.4 \times 10^2 \text{ m s}^{-1}$

### REFRACTIVE INDICES

The refractive indices refer to sodium light of wavelength 589 nm and to substances at a temperature of 273 K.

Substance	Refractive index	Substance	Refractive index
Diamond	2.42	Glycerol	1.47
Glass	1.51	Water	1.33
Ice	1.31	Air	1.00
Perspex	1.49	Magnesium Fluoride	1.38

### SPECTRAL LINES

Element	Wavelength/nm	Colour	Element	Wavelength/nm	Colour
Hydrogen	656	Red	Cadmium	644	Red
	486	Blue-green		509	Green
	434	Blue-violet		480	Blue
	410	Violet	<i>Lasers</i>		
	397	Ultraviolet	<i>Element</i>	<i>Wavelength/nm</i>	<i>Colour</i>
	389	Ultraviolet	Carbon dioxide	9550 } 10590 }	Infrared
Sodium	589	Yellow	Helium-neon	633	Red

### PROPERTIES OF SELECTED MATERIALS

Substance	Density/ $\text{kg m}^{-3}$	Melting Point/ K	Boiling Point/ K	Specific Heat Capacity/ $\text{J kg}^{-1} \text{ K}^{-1}$	Specific Latent Heat of Fusion/ $\text{J kg}^{-1}$	Specific Latent Heat of Vaporisation/ $\text{J kg}^{-1}$
Aluminium	$2.70 \times 10^3$	933	2623	$9.02 \times 10^2$	$3.95 \times 10^5$	....
Copper	$8.96 \times 10^3$	1357	2853	$3.86 \times 10^2$	$2.05 \times 10^5$	....
Glass	$2.60 \times 10^3$	1400	....	$6.70 \times 10^2$	....	....
Ice	$9.20 \times 10^2$	273	....	$2.10 \times 10^3$	$3.34 \times 10^5$	....
Glycerol	$1.26 \times 10^3$	291	563	$2.43 \times 10^3$	$1.81 \times 10^5$	$8.30 \times 10^5$
Methanol	$7.91 \times 10^2$	175	338	$2.52 \times 10^3$	$9.9 \times 10^4$	$1.12 \times 10^6$
Sea Water	$1.02 \times 10^3$	264	377	$3.93 \times 10^3$	....	....
Water	$1.00 \times 10^3$	273	373	$4.18 \times 10^3$	$3.34 \times 10^5$	$2.26 \times 10^6$
Air	1.29	....	....	....	....	....
Hydrogen	$9.0 \times 10^{-2}$	14	20	$1.43 \times 10^4$	....	$4.50 \times 10^5$
Nitrogen	1.25	63	77	$1.04 \times 10^3$	....	$2.00 \times 10^5$
Oxygen	1.43	55	90	$9.18 \times 10^2$	....	$2.40 \times 10^4$

The gas densities refer to a temperature of 273 K and a pressure of  $1.01 \times 10^5 \text{ Pa}$ .



\* X 7 5 7 7 7 0 1 0 2 \*

1. An athlete competes in a one hundred metre race on a flat track, as shown in Figure 1A.



Figure 1A

Starting from rest, the athlete's speed for the first 3.10 seconds of the race can be modelled using the relationship

$$v = 0.4t^2 + 2t$$

where the symbols have their usual meaning.

According to this model:

- (a) determine the speed of the athlete at  $t = 3.10$  s;

2

*Space for working and answer*

- (b) determine, using **calculus** methods, the distance travelled by the athlete in this time.

3

*Space for working and answer*



2. (a) As part of a lesson, a teacher swings a sphere tied to a light string as shown in Figure 2A. The path of the sphere is a vertical circle as shown in Figure 2B.

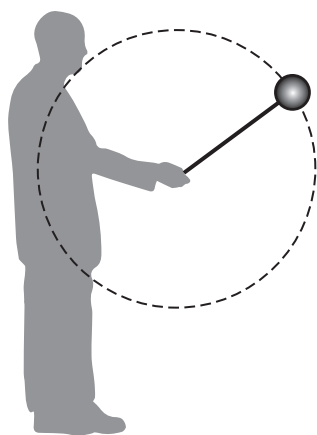

Figure 2A

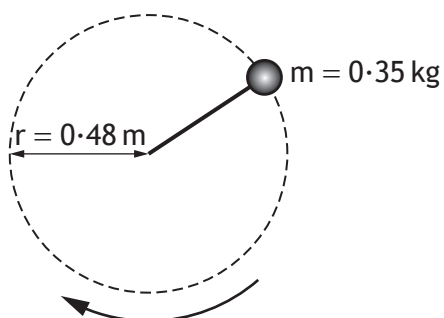

Figure 2B

- (i) On Figure 2C, show the forces acting on the sphere as it passes through its highest point.

You must name these forces and show their directions.

1

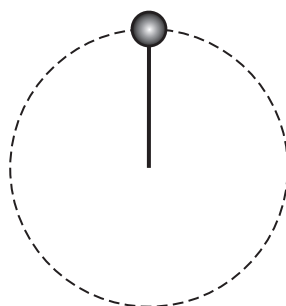

Figure 2C



2. (a) (continued)

- (ii) On Figure 2D, show the forces acting on the sphere as it passes through its lowest point.

You must name these forces and show their directions.

1

Figure 2D

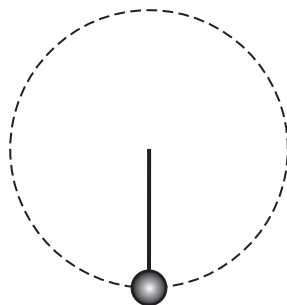

- (iii) The sphere of mass  $0.35 \text{ kg}$  can be considered to be moving at a constant speed.

The centripetal force acting on the sphere is  $4.0 \text{ N}$ .

Determine the magnitude of the tension in the light string when the sphere is at:

- (A) the highest position in its circular path;

2

*Space for working and answer*

- (B) the lowest position in its circular path.

1

*Space for working and answer*



\* X 7 5 7 7 7 0 1 0 5 \*

2. (continued)

- (b) The speed of the sphere is now gradually reduced until the sphere no longer travels in a circular path.

Explain why the sphere no longer travels in a circular path.

2

- (c) The teacher again swings the sphere with constant speed in a vertical circle. The student shown in Figure 2E observes the sphere moving up and down vertically with simple harmonic motion.

The period of this motion is 1.4 s.

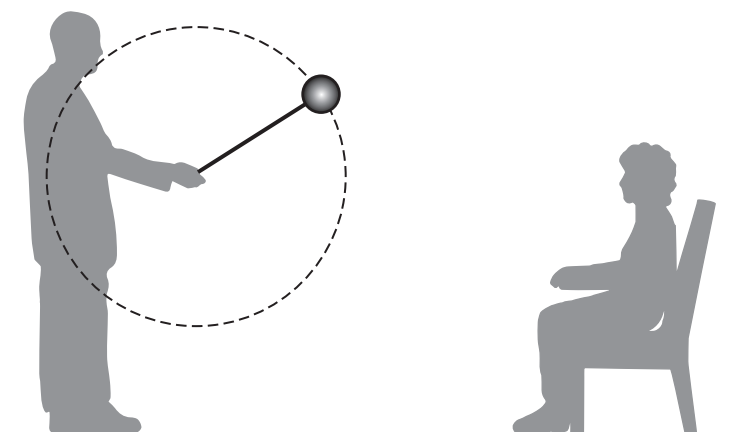

Figure 2E

Figure 2F represents the path of the sphere as observed by the student.

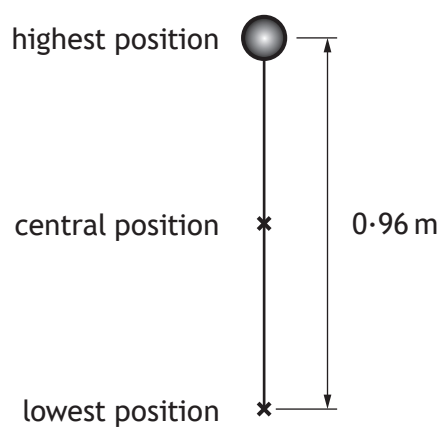

Figure 2F



2. (c) (continued)

On Figure 2G, sketch a graph showing how the vertical displacement  $s$  of the sphere from its central position varies with time  $t$ , as it moves from its highest position to its lowest position.

Numerical values are required on both axes.

3



Figure 2G

(An additional diagram, if required, can be found on *Page 42*.)

[Turn over



3. A student uses a solid, uniform circular disc of radius 290 mm and mass 0.40 kg as part of an investigation into rotational motion.

The disc is shown in Figure 3A.

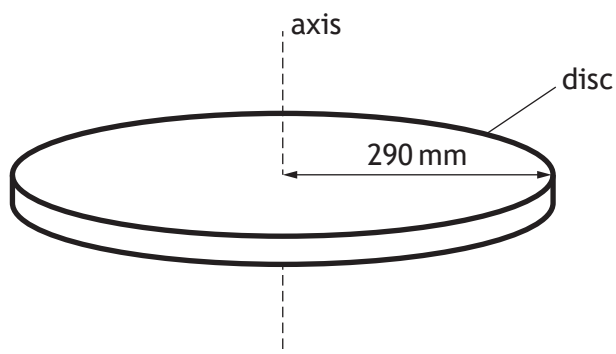

Figure 3A

- (a) Calculate the moment of inertia of the disc about the axis shown in Figure 3A.

3

*Space for working and answer*



\* X 7 5 7 7 7 0 1 0 8 \*

3. (continued)

MARKS

DO NOT  
WRITE IN  
THIS  
MARGIN

- (b) The disc is now mounted horizontally on the axle of a rotational motion sensor as shown in Figure 3B.

The axle is on a frictionless bearing. A thin cord is wound around a stationary pulley which is attached to the axle.

The moment of inertia of the pulley and axle can be considered negligible.

The pulley has a radius of 7.5 mm and a force of 8.0 N is applied to the free end of the cord.

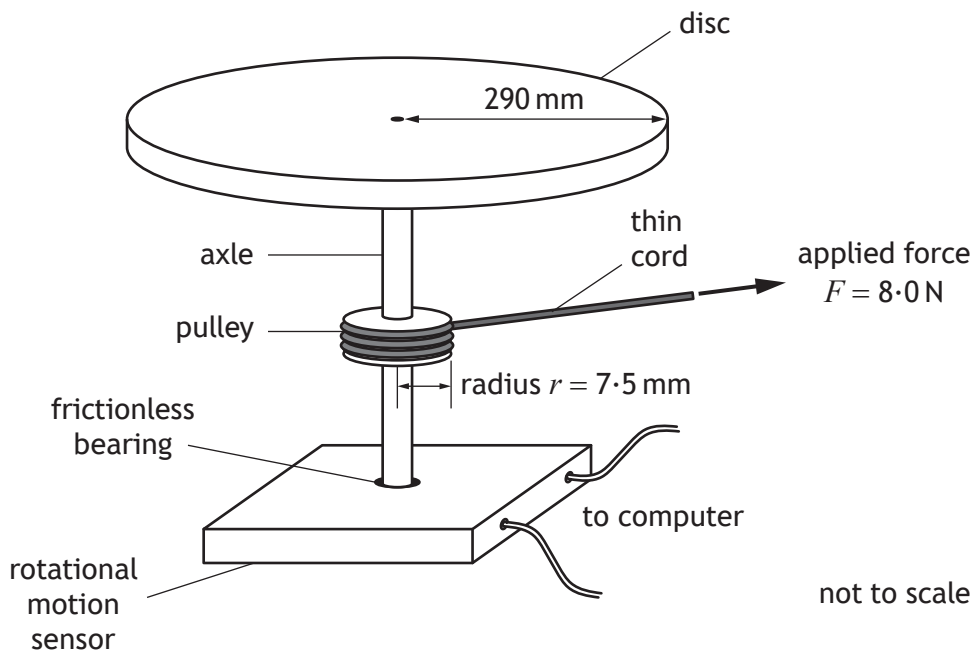

Figure 3B

- (i) Calculate the torque applied to the pulley.

3

*Space for working and answer*

- (ii) Calculate the angular acceleration produced by this torque.

3

*Space for working and answer*



\* X 7 5 7 7 7 0 1 0 9 \*

MARKS

DO NOT  
WRITE IN  
THIS  
MARGIN

3. (b) (continued)

(iii) The cord becomes detached from the pulley after 0.25 m has unwound.

By considering the angular displacement of the disc, determine its angular velocity when the cord becomes detached.

5

*Space for working and answer*



\* X 7 5 7 7 7 0 1 1 0 \*

3. (continued)

- (c) In a second experiment the disc has an angular velocity of  $12 \text{ rad s}^{-1}$ .  
 The student now drops a small 25 g cube vertically onto the disc. The cube sticks to the disc.  
 The centre of mass of the cube is 220 mm from the axis of rotation, as shown in Figure 3C.

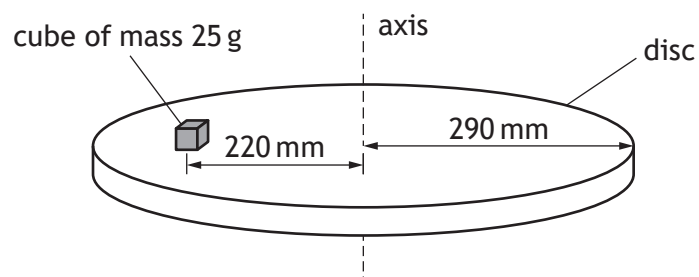

Figure 3C

Calculate the angular velocity of the system immediately after the cube was dropped onto the disc.

5

*Space for working and answer*



4. The NASA space probe Dawn has travelled to and orbited large asteroids in the solar system. Dawn has a mass of 1240 kg.

The table gives information about two large asteroids orbited by Dawn. Both asteroids can be considered to be spherical and remote from other large objects.

<i>Name</i>	<i>Mass (<math>\times 10^{20}</math> kg)</i>	<i>Radius (km)</i>
Vesta	2.59	263
Ceres	9.39	473

- (a) Dawn began orbiting Vesta, in a circular orbit, at a height of 680 km above the surface of the asteroid. The gravitational force acting on Dawn at this altitude was 24.1 N.

- (i) Show that the tangential velocity of Dawn in this orbit is  $135 \text{ m s}^{-1}$ . 2  
*Space for working and answer*

- (ii) Calculate the orbital period of Dawn. 3  
*Space for working and answer*



4. (continued)

(b) Later in its mission, Dawn entered orbit around Ceres. It then moved from a high orbit to a lower orbit around the asteroid.

(i) State what is meant by the *gravitational potential of a point in space*. 1

(ii) Dawn has a gravitational potential of  $-1.29 \times 10^4 \text{ J kg}^{-1}$  in the high orbit and a gravitational potential of  $-3.22 \times 10^4 \text{ J kg}^{-1}$  in the lower orbit.

Determine the change in the potential energy of Dawn as a result of this change in orbit. 4

*Space for working and answer*



\* X 7 5 7 7 7 0 1 1 3 \*

5. Two students are discussing objects escaping from the gravitational pull of the Earth. They make the following statements:

Student 1: A rocket has to accelerate until it reaches the escape velocity of the Earth in order to escape its gravitational pull.

Student 2: The moon is travelling slower than the escape velocity of the Earth and yet it has escaped.

Use your knowledge of physics to comment on these statements.

3



\* X 7 5 7 7 7 0 1 1 4 \*

[Turn over for next question

DO NOT WRITE ON THIS PAGE



\* X 7 5 7 7 7 0 1 1 5 \*

6. A Hertzsprung-Russell (H-R) diagram is shown in Figure 6A.

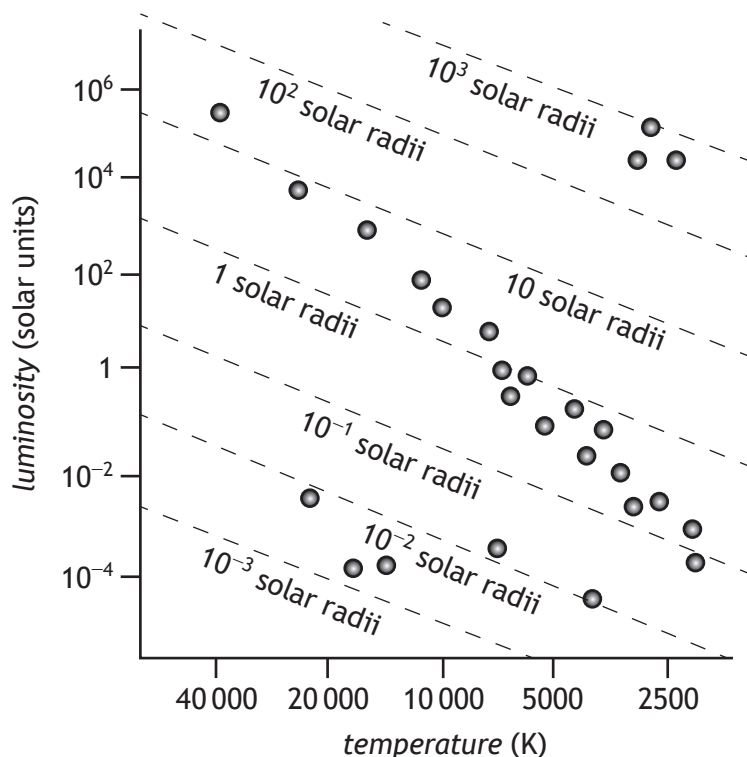
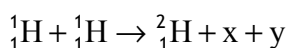

Figure 6A

- (a) All stars on the main sequence release energy by converting hydrogen to helium. This process is known as the proton-proton (p-p) chain. One stage in the p-p chain is shown.



Name particles x and y.

2

- (b) The luminosity of the Sun is  $3.9 \times 10^{26}$  W. The star Procyon B has a luminosity of  $4.9 \times 10^{-4}$  solar units and a radius of  $1.2 \times 10^{-2}$  solar radii.

- (i) On the H-R diagram, circle the star at the position of Procyon B.

1

(An additional diagram, if required, can be found on Page 42.)

- (ii) What type of star is Procyon B?

1



\* X 7 5 7 7 7 0 1 1 6 \*

6. (b) (continued)

(iii) The apparent brightness of Procyon B when viewed from Earth is  $1.3 \times 10^{-12} \text{ W m}^{-2}$ .

Calculate the distance of Procyon B from Earth.

4

*Space for working and answer*

(c) The expression

$$\frac{L}{L_0} = 1.5 \left( \frac{M}{M_0} \right)^{3.5}$$

can be used to approximate the relationship between a star's mass  $M$  and its luminosity  $L$ .

$L_0$  is the luminosity of the Sun (1 solar unit) and  $M_0$  is the mass of the Sun.

This expression is valid for stars of mass between  $2M_0$  and  $20M_0$ .

Spica is a star which has mass  $10.3M_0$ .

Determine the approximate luminosity of Spica in solar units.

2

*Space for working and answer*



\* X 7 5 7 7 7 0 1 1 7 \*

7. Laser light is often described as having a single frequency. However, in practice a laser will emit photons with a range of frequencies.

Quantum physics links the frequency of a photon to its energy.

Therefore the photons emitted by a laser have a range of energies ( $\Delta E$ ). The range of photon energies is related to the lifetime ( $\Delta t$ ) of the atom in the excited state.

A graph showing the variation of intensity with frequency for light from two types of laser is shown in Figure 7A.

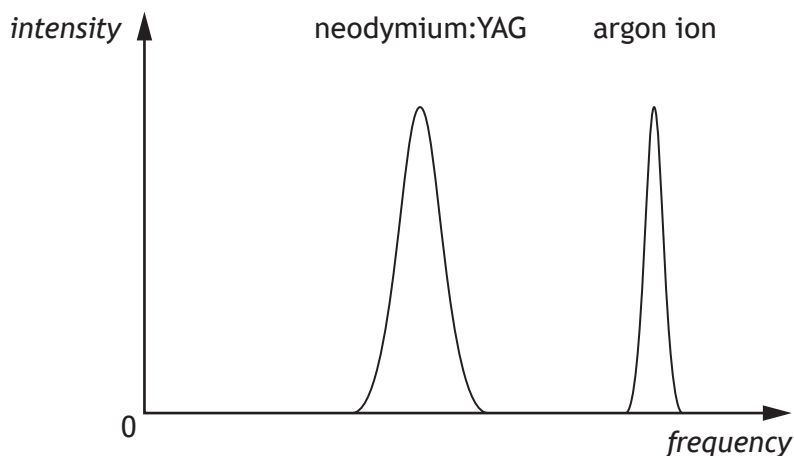

Figure 7A

- (a) By considering the Heisenberg uncertainty principle, state how the lifetime of atoms in the excited state in the neodymium:YAG laser compares with the lifetime of atoms in the excited state in the argon ion laser.

Justify your answer.

2



7. (continued)

(b) In another type of laser, an atom is in the excited state for a time of  $5.0 \times 10^{-6}$  s.

(i) Calculate the minimum uncertainty in the energy ( $\Delta E_{\min}$ ) of a photon emitted when the atom returns to its unexcited state. 3

*Space for working and answer*

(ii) Determine a value for the range of frequencies ( $\Delta f$ ) of the photons emitted by this laser. 3

*Space for working and answer*



\* X 7 5 7 7 7 0 1 1 9 \*

8. A student is investigating simple harmonic motion. An oscillating mass on a spring, and a motion sensor connected to a computer, are used in the investigation. This is shown in Figure 8A.

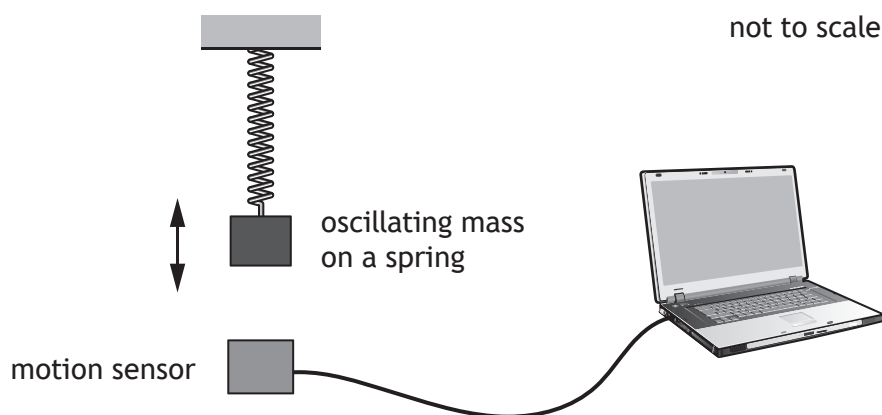

Figure 8A

The student raises the mass from its rest position and then releases it. The computer starts recording data when the mass is released.

- (a) The student plans to model the displacement  $y$  of the mass from its rest position, using the expression

$$y = A \sin \omega t$$

where the symbols have their usual meaning.

Explain why the student is incorrect.

1



8. (continued)

- (b) (i) The unbalanced force acting on the mass is given by the expression

$$F = -m\omega^2 y$$

Hooke's Law is given by the expression

$$F = -ky$$

where  $k$  is the spring constant.

By comparing these expressions, show that the frequency of the oscillation can be described by the relationship

$$f = \frac{1}{2\pi} \sqrt{\frac{k}{m}}$$

2

- (ii) The student measures the mass to be 0.50 kg and the period of oscillation to be 0.80 s.

Determine a value for the spring constant  $k$ .

3

*Space for working and answer*



\* X 7 5 7 7 7 0 1 2 1 \*

8. (b) (continued)

(iii) The student plans to repeat the experiment using the same mass and a second spring, which has a spring constant twice the value of the original.

Determine the expected period of oscillation of the mass.

2

(c) The student obtains graphs showing the variation of displacement with time, velocity with time and acceleration with time.

The student forgets to label the y-axis for each graph.

Complete the labelling of the y-axis of each graph in Figure 8B.

2

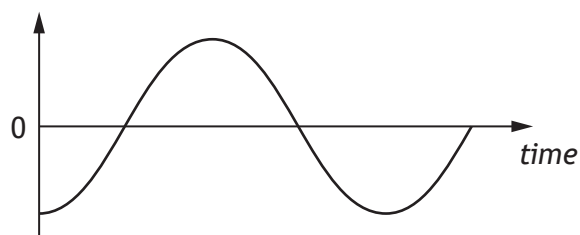

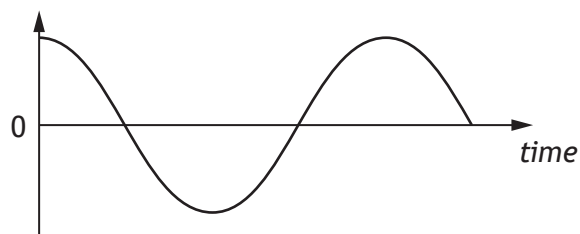

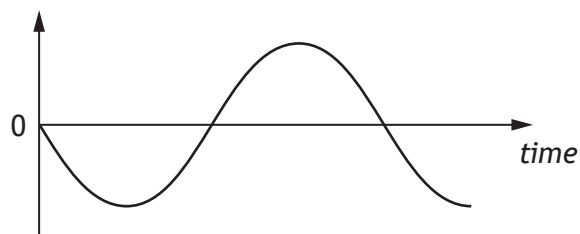

Figure 8B



9. A wave travelling along a string is represented by the relationship

$$y = 9.50 \times 10^{-4} \sin(922t - 4.50x)$$

(a) (i) Show that the frequency of the wave is 147 Hz.

*Space for working and answer*

1

(ii) Determine the speed of the wave.

*Space for working and answer*

4

(iii) The wave loses energy as it travels along the string.

At one point, the energy of the wave has decreased to one eighth of its original value.

Calculate the amplitude of the wave at this point.

*Space for working and answer*

3



\* X 7 5 7 7 7 0 1 2 3 \*

9. (continued)

(b) The speed of a wave on a string can also be described by the relationship

$$v = \sqrt{\frac{T}{\mu}}$$

where  $v$  is the speed of the wave,

$T$  is the tension in the string, and

$\mu$  is the mass per unit length of the string.

A string of length 0.69 m has a mass of  $9.0 \times 10^{-3}$  kg.

A wave is travelling along the string with a speed of  $203 \text{ m s}^{-1}$ .

Calculate the tension in the string.

3

*Space for working and answer*



\* X 7 5 7 7 7 0 1 2 4 \*

9. (continued)

(c) When a string is fixed at both ends and plucked, a stationary wave is produced.

(i) Explain briefly, in terms of the superposition of waves, how the stationary wave is produced.

1

(ii) The string is vibrating at its fundamental frequency of 270 Hz and produces the stationary wave pattern shown in Figure 9A.

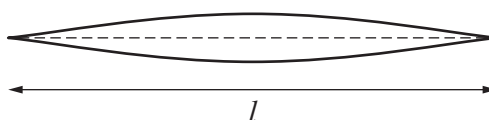

Figure 9A

Figure 9B shows the same string vibrating at a frequency called its third harmonic.

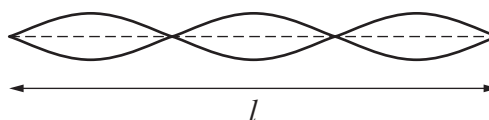

Figure 9B

Determine the frequency of the third harmonic.

1



[BLANK PAGE]

DO NOT WRITE ON THIS PAGE



\* X 7 5 7 7 7 0 1 2 6 \*

10. The internal structure of some car windscreens produces an effect which can be likened to that obtained by slits in a grating.

A passenger in a car observes a distant red traffic light and notices that the red light is surrounded by a pattern of bright spots.

This is shown in Figure 10A.

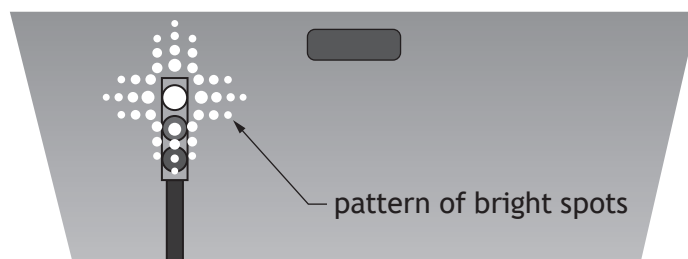

Figure 10A

- (a) Explain how the **two-dimensional** pattern of bright spots shown in Figure 10A is produced.

2

- (b) The traffic light changes to green. Apart from colour, state a difference that would be observed in the pattern of bright spots.

Justify your answer.

2



10. (continued)

- (c) An LED from the traffic light is tested to determine the wavelength by shining its light through a set of Young's double slits, as shown in Figure 10B.

The fringe separation is  $(13.0 \pm 0.5)$  mm and the double slit separation is  $(0.41 \pm 0.01)$  mm.

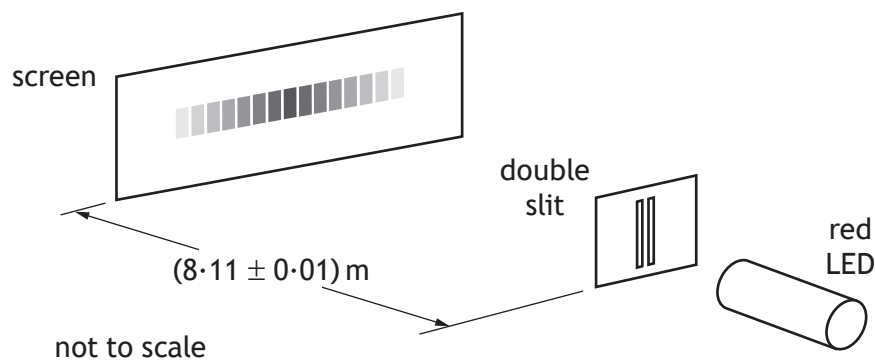

Figure 10B

- (i) Calculate the wavelength of the light from the LED.

3

*Space for working and answer*



10. (c) (continued)

(ii) Determine the absolute uncertainty in this wavelength.

5

*Space for working and answer*

(iii) The experiment is now repeated with the screen moved further away from the slits.

Explain why this is the most effective way of reducing the uncertainty in the calculated value of the wavelength.

1



\* X 7 5 7 7 7 0 1 2 9 \*

11. (a) State what is meant by the term *electric field strength*.

1

(b) A, B, C and D are the vertices of a square of side 0.12 m.

Two +4.0 nC point charges are placed at positions B and D as shown in Figure 11A.

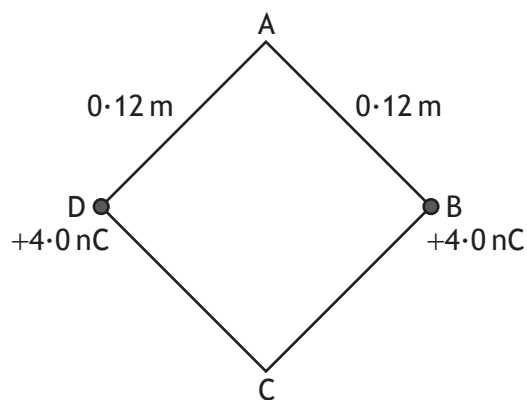

Figure 11A

(i) Show that the magnitude of the electric field strength at position A is  $3.5 \times 10^3 \text{ N C}^{-1}$ .

3

*Space for working and answer*



11. (b) (continued)

- |  |          |
|--|----------|
| <p>(ii) A <math>+1.9 \text{ nC}</math> point charge is placed at position A.<br/>Calculate the magnitude of the force acting on this charge.<br/><i>Space for working and answer</i></p>   | <p>3</p> |
| <p>(iii) State the direction of the force acting on this charge.</p>   | <p>1</p> |
| <p>(iv) A fourth point charge is now placed at position C so that the resultant force on the charge at position A is zero.<br/>Determine the magnitude of the charge placed at position C.<br/><i>Space for working and answer</i></p> | <p>4</p> |



12. A velocity selector is used as the initial part of a larger apparatus that is designed to measure properties of ions of different elements.

The velocity selector has a region in which there is a uniform electric field and a uniform magnetic field. These fields are perpendicular to each other and also perpendicular to the initial velocity  $v$  of the ions.

This is shown in Figure 12A.

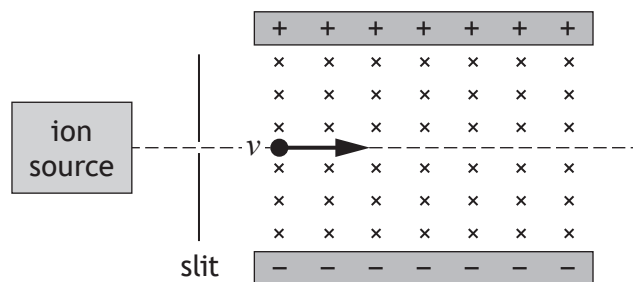

Figure 12A

A beam of chlorine ions consists of a number of isotopes including  $^{35}\text{Cl}^+$ .

The magnitude of the charge on a  $^{35}\text{Cl}^+$  ion is  $1.60 \times 10^{-19} \text{ C}$ .

The magnitude of electric force on a  $^{35}\text{Cl}^+$  chlorine ion is  $4.00 \times 10^{-15} \text{ N}$ .

The ions enter the apparatus with a range of speeds.

The magnetic induction is 115 mT.

- (a) State the direction of the magnetic force on a  $^{35}\text{Cl}^+$  ion. 1

- (b) By considering the electric and magnetic forces acting on a  $^{35}\text{Cl}^+$  ion, determine the speed of the  $^{35}\text{Cl}^+$  ions that will pass through the apparatus without being deflected. 3

*Space for working and answer*



12. (continued)

- (c)  $^{35}\text{Cl}^+$  ions that are travelling at a velocity less than that determined in (b) are observed to follow the path shown in Figure 12B.

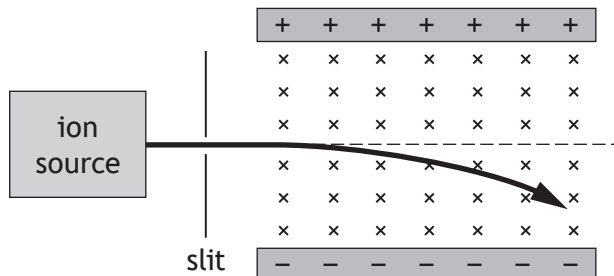

Figure 12B

Explain, in terms of their velocity, why these ions follow this path.

2

- (d)  $^{37}\text{Cl}^{2+}$  ions are also present in the beam.  $^{37}\text{Cl}^{2+}$  ions have a greater mass and a greater charge than  $^{35}\text{Cl}^+$  ions. Some  $^{37}\text{Cl}^{2+}$  ions also pass through the apparatus without being deflected.

State the speed of these ions.

You must justify your answer.

2



13. A student purchases a capacitor with capacitance  $1.0\text{ F}$ . The capacitor, which has negligible resistance, is used to supply short bursts of energy to the audio system in a car when there is high energy demand on the car battery.

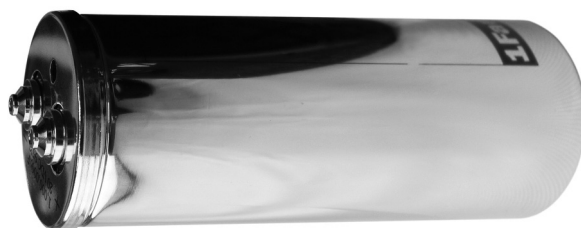

The instructions state that the capacitor must be fully charged from the  $12\text{ V d.c.}$  car battery through a  $1.0\text{ k}\Omega$  series resistor.

- (a) Show that the time constant for this charging circuit is  $1.0 \times 10^3\text{ s}$ . 2  
*Space for working and answer*



13. (continued)

(b) The student carries out an experiment to monitor the voltage across the capacitor while it is being charged.

(i) Draw a diagram of the circuit which would enable the student to carry out this experiment.

1

(ii) The student draws the graph shown in Figure 13A.

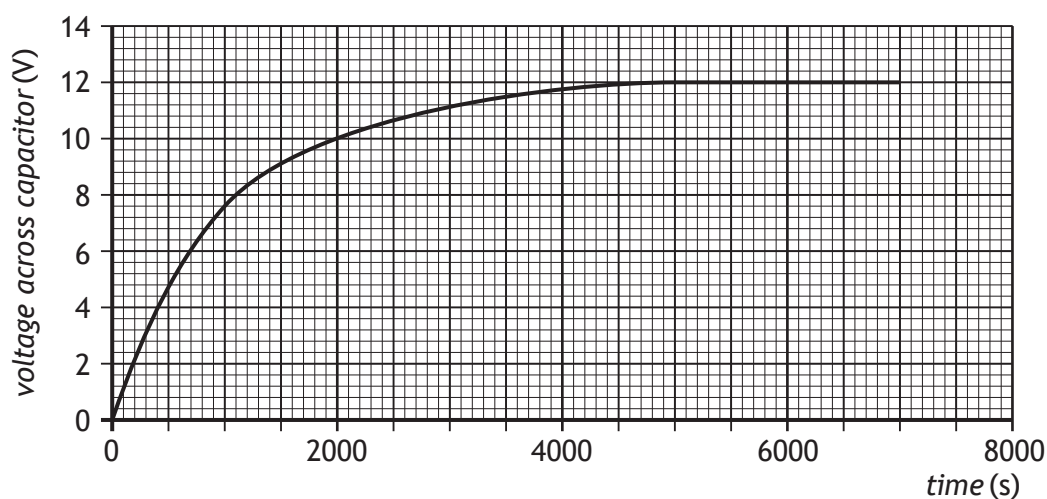

Figure 13A

(A) Use information from the graph to show that the capacitor is 63% charged after 1 time constant.

2

*Space for working and answer*

(B) Use information from the graph to determine how many time constants are required for this capacitor to be considered fully charged

1



MARKS

DO NOT  
WRITE IN  
THIS  
MARGIN

13. (continued)

(c) The car audio system is rated at 12 V, 20 W.

Use your knowledge of physics to comment on the suitability of the capacitor as the only energy source for the audio system.

3



\* X 7 5 7 7 7 0 1 3 6 \*

[Turn over for next question

DO NOT WRITE ON THIS PAGE



\* X 7 5 7 7 7 0 1 3 7 \*

14. A student designs a loudspeaker circuit.

A capacitor and an inductor are used in the circuit so that high frequency signals are passed to a small “tweeter” loudspeaker and low frequency signals are passed to a large “woofer” loudspeaker.

Each loudspeaker has a resistance of  $8.0\ \Omega$ .

The circuit diagram is shown in Figure 14A.

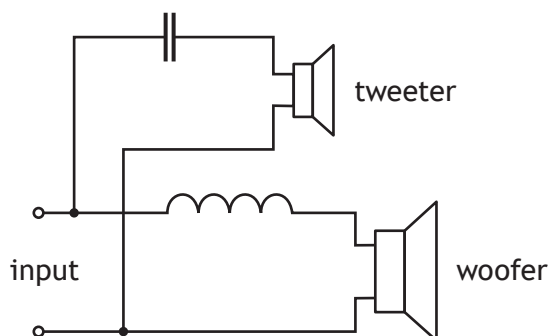

Figure 14A

The circuit is designed to have a “crossover” frequency of  $3.0\ \text{kHz}$ : at frequencies above  $3.0\ \text{kHz}$  there is a greater current in the tweeter and at frequencies below  $3.0\ \text{kHz}$  there is a greater current in the woofer.

(a) Explain how the use of a capacitor and an inductor allows:

(i) high frequency signals to be passed to the tweeter;

1

(ii) low frequency signals to be passed to the woofer.

1



14. (continued)

- (b) At the crossover frequency, both the reactance of the capacitor and the reactance of the inductor are equal to the resistance of each loudspeaker.

Calculate the inductance required to provide an inductive reactance of  $8.0\ \Omega$  when the frequency of the signal is  $3.0\ \text{kHz}$ .

3

*Space for working and answer*



\* X 7 5 7 7 7 0 1 3 9 \*

## 14. (continued)

- (c) In a box of components, the student finds an inductor and decides to determine its inductance. The student constructs the circuit shown in Figure 14B.

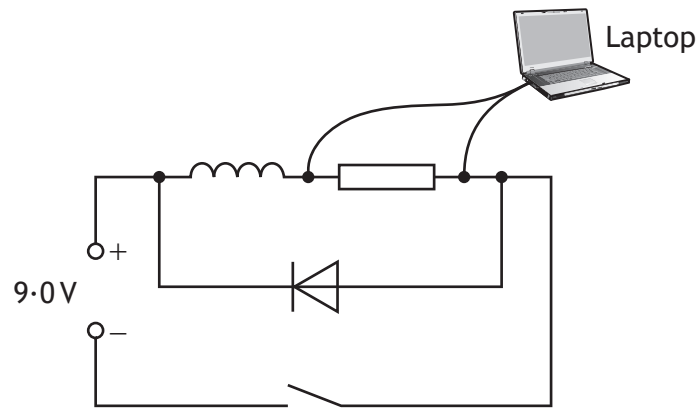

Figure 14B

The student obtains data from the experiment and presents the data on the graph shown in Figure 14C.

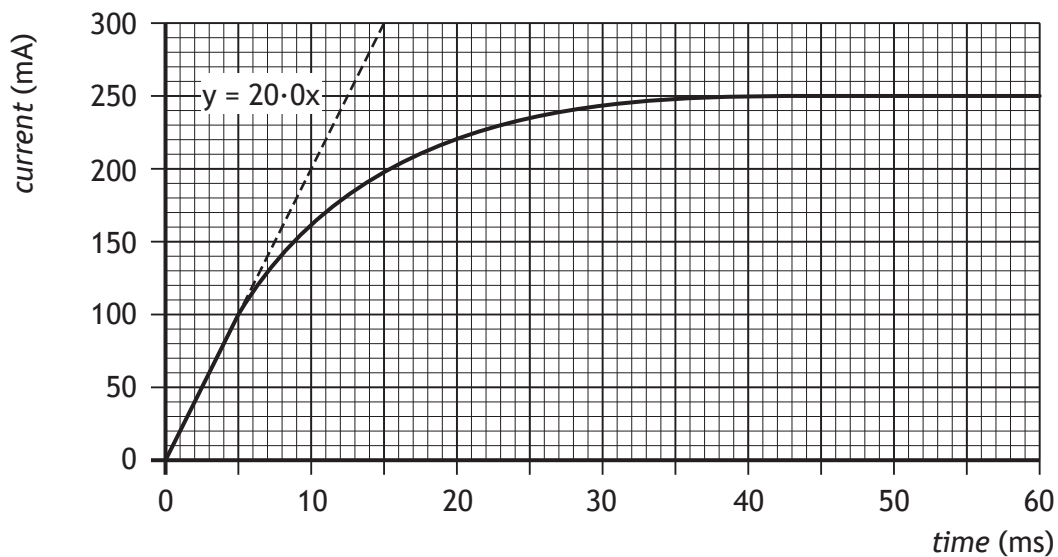

Figure 14C



\* X 7 5 7 7 7 0 1 4 0 \*

MARKS

DO NOT  
WRITE IN  
THIS  
MARGIN

14. (c) (continued)

(i) Determine the inductance of the inductor.

4

*Space for working and answer*

(ii) The student was advised to include a diode in the circuit to prevent damage to the laptop when the switch is opened.

1

Explain why this is necessary.

[END OF QUESTION PAPER]



\* X 7 5 7 7 7 0 1 4 1 \*

Additional diagram for question 2 (c)



Figure 2G

Additional diagram for question 6 (b) (i)

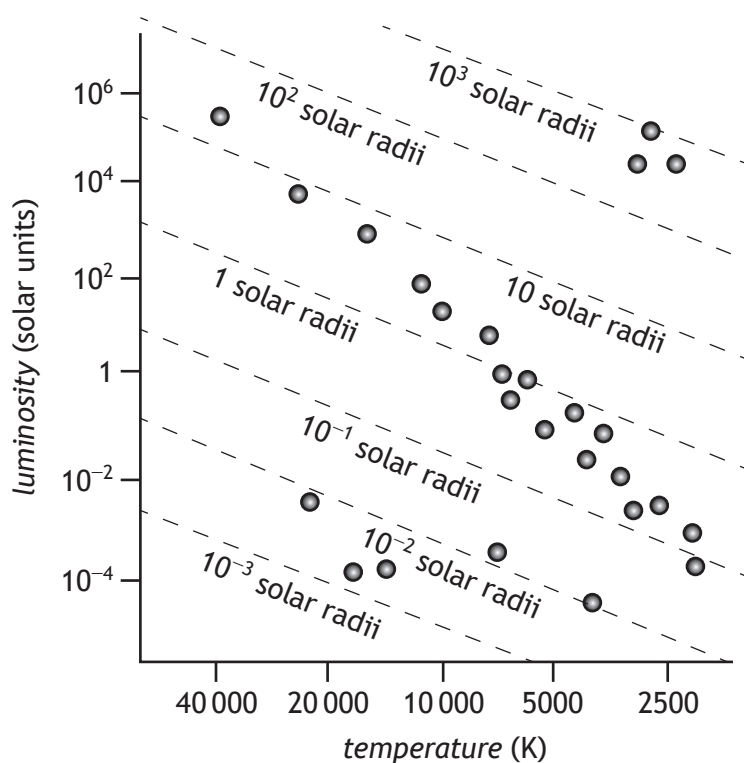
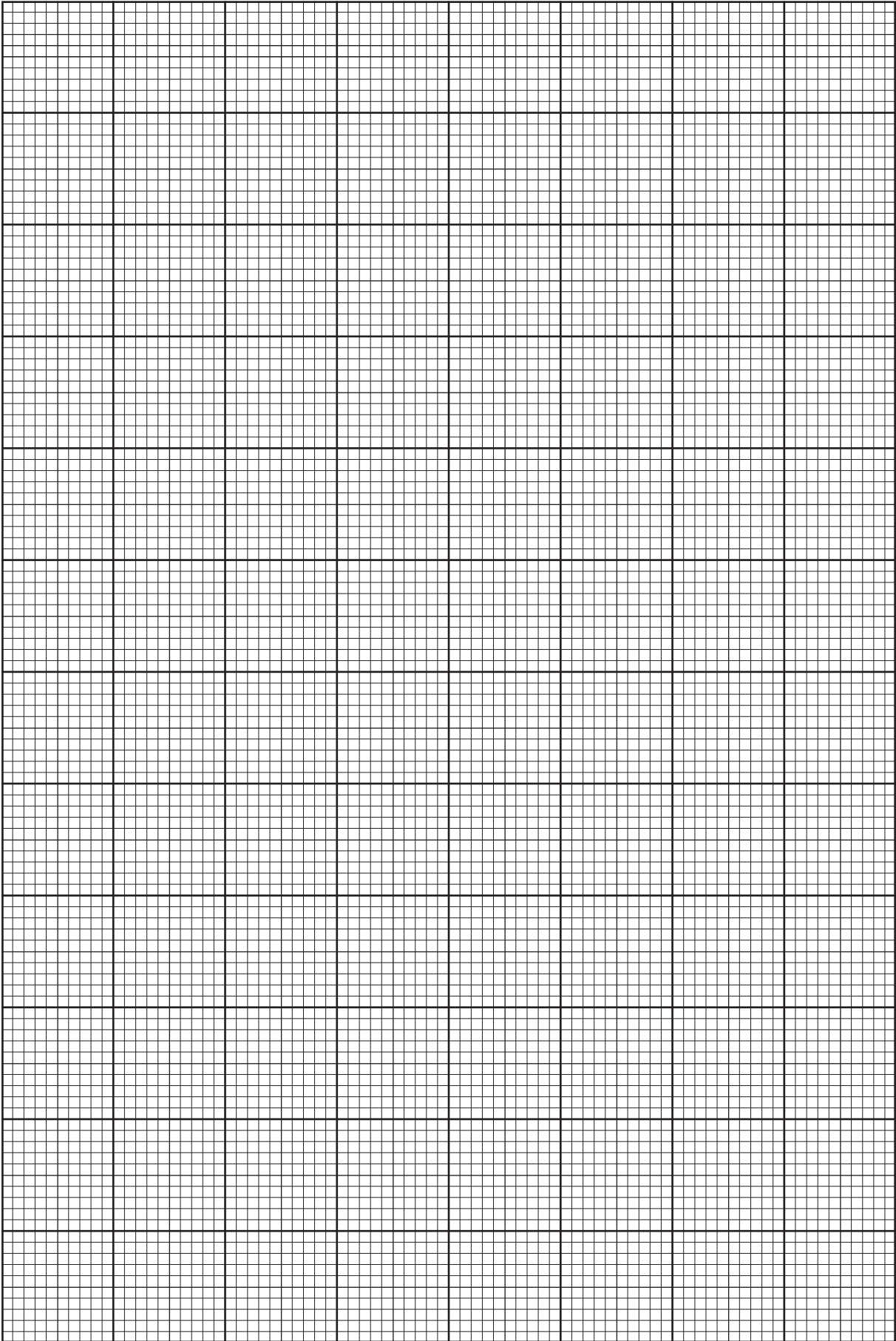

Figure 6A



\* X 7 5 7 7 7 0 1 4 2 \*



\* X 7 5 7 7 7 0 1 4 3 \*

MARKS

DO NOT  
WRITE IN  
THIS  
MARGIN

ADDITIONAL SPACE FOR ANSWERS AND ROUGH WORK



\* X 7 5 7 7 7 0 1 4 4 \*

MARKS

DO NOT  
WRITE IN  
THIS  
MARGIN

ADDITIONAL SPACE FOR ANSWERS AND ROUGH WORK



\* X 7 5 7 7 7 0 1 4 5 \*

MARKS

DO NOT  
WRITE IN  
THIS  
MARGIN

ADDITIONAL SPACE FOR ANSWERS AND ROUGH WORK



\* X 7 5 7 7 7 0 1 4 6 \*

[BLANK PAGE]

DO NOT WRITE ON THIS PAGE



\* X 7 5 7 7 7 0 1 4 7 \*

[BLANK PAGE]

DO NOT WRITE ON THIS PAGE

*Acknowledgement of Copyright*

Question 1      Diego Barbieri/shutterstock.com

Question 13    Vasca/shutterstock.com



\* X 7 5 7 7 7 0 1 4 8 \*