

FOR OFFICIAL USE



--	--	--	--	--	--

National
Qualifications
2018

Mark

--

X757/77/01

Physics

TUESDAY, 8 MAY
9:00 AM – 11:30 AM



* X 7 5 7 7 7 0 1 *

Fill in these boxes and read what is printed below.

Full name of centre

--

Town

--

Forename(s)

--

Surname

--

Number of seat

--

Date of birth

Day

Month

Year

--	--

--	--

--	--

Scottish candidate number

--	--	--	--	--	--	--	--	--	--

Total marks — 140

Attempt ALL questions.

Reference may be made to the Physics Relationships Sheet X757/77/11 and the Data Sheet on page 02.

Write your answers clearly in the spaces provided in this booklet. Additional space for answers and rough work is provided at the end of this booklet. If you use this space you must clearly identify the question number you are attempting. Any rough work must be written in this booklet. You should score through your rough work when you have written your final copy.

Care should be taken to give an appropriate number of significant figures in the final answers to calculations.

Use **blue** or **black** ink.

Before leaving the examination room you must give this booklet to the Invigilator; if you do not, you may lose all the marks for this paper.



* X 7 5 7 7 7 0 1 0 1 *

DATA SHEET

COMMON PHYSICAL QUANTITIES

Quantity	Symbol	Value	Quantity	Symbol	Value
Gravitational acceleration on Earth	g	9.8 m s^{-2}	Mass of electron	m_e	$9.11 \times 10^{-31} \text{ kg}$
Radius of Earth	R_E	$6.4 \times 10^6 \text{ m}$	Charge on electron	e	$-1.60 \times 10^{-19} \text{ C}$
Mass of Earth	M_E	$6.0 \times 10^{24} \text{ kg}$	Mass of neutron	m_n	$1.675 \times 10^{-27} \text{ kg}$
Mass of Moon	M_M	$7.3 \times 10^{22} \text{ kg}$	Mass of proton	m_p	$1.673 \times 10^{-27} \text{ kg}$
Radius of Moon	R_M	$1.7 \times 10^6 \text{ m}$	Mass of alpha particle	m_α	$6.645 \times 10^{-27} \text{ kg}$
Mean Radius of Moon Orbit		$3.84 \times 10^8 \text{ m}$	Charge on alpha particle		$3.20 \times 10^{-19} \text{ C}$
Solar radius		$6.955 \times 10^8 \text{ m}$	Planck's constant	h	$6.63 \times 10^{-34} \text{ J s}$
Mass of Sun		$2.0 \times 10^{30} \text{ kg}$	Permittivity of free space	ϵ_0	$8.85 \times 10^{-12} \text{ F m}^{-1}$
1 AU		$1.5 \times 10^{11} \text{ m}$	Permeability of free space	μ_0	$4\pi \times 10^{-7} \text{ H m}^{-1}$
Stefan-Boltzmann constant	σ	$5.67 \times 10^{-8} \text{ W m}^{-2} \text{ K}^{-4}$	Speed of light in vacuum	c	$3.00 \times 10^8 \text{ m s}^{-1}$
Universal constant of gravitation	G	$6.67 \times 10^{-11} \text{ m}^3 \text{ kg}^{-1} \text{ s}^{-2}$	Speed of sound in air	v	$3.4 \times 10^2 \text{ m s}^{-1}$

REFRACTIVE INDICES

The refractive indices refer to sodium light of wavelength 589 nm and to substances at a temperature of 273 K.

Substance	Refractive index	Substance	Refractive index
Diamond	2.42	Glycerol	1.47
Glass	1.51	Water	1.33
Ice	1.31	Air	1.00
Perspex	1.49	Magnesium Fluoride	1.38

SPECTRAL LINES

Element	Wavelength/nm	Colour	Element	Wavelength/nm	Colour
Hydrogen	656	Red	Cadmium	644	Red
	486	Blue-green		509	Green
	434	Blue-violet		480	Blue
	410	Violet	<i>Lasers</i>		
	397	Ultraviolet	<i>Element</i>	<i>Wavelength/nm</i>	<i>Colour</i>
	389	Ultraviolet	Carbon dioxide	9550 } 10590 }	Infrared
Sodium	589	Yellow	Helium-neon	633	Red

PROPERTIES OF SELECTED MATERIALS

Substance	Density/ kg m^{-3}	Melting Point/ K	Boiling Point/ K	Specific Heat Capacity/ $\text{J kg}^{-1} \text{ K}^{-1}$	Specific Latent Heat of Fusion/ J kg^{-1}	Specific Latent Heat of Vaporisation/ J kg^{-1}
Aluminium	2.70×10^3	933	2623	9.02×10^2	3.95×10^5
Copper	8.96×10^3	1357	2853	3.86×10^2	2.05×10^5
Glass	2.60×10^3	1400	6.70×10^2
Ice	9.20×10^2	273	2.10×10^3	3.34×10^5
Glycerol	1.26×10^3	291	563	2.43×10^3	1.81×10^5	8.30×10^5
Methanol	7.91×10^2	175	338	2.52×10^3	9.9×10^4	1.12×10^6
Sea Water	1.02×10^3	264	377	3.93×10^3
Water	1.00×10^3	273	373	4.18×10^3	3.34×10^5	2.26×10^6
Air	1.29
Hydrogen	9.0×10^{-2}	14	20	1.43×10^4	4.50×10^5
Nitrogen	1.25	63	77	1.04×10^3	2.00×10^5
Oxygen	1.43	55	90	9.18×10^2	2.40×10^4

The gas densities refer to a temperature of 273 K and a pressure of $1.01 \times 10^5 \text{ Pa}$.



* X 7 5 7 7 7 0 1 0 2 *

1. Energy is stored in a clockwork toy car by winding-up an internal spring using a key. The car is shown in Figure 1A.



Figure 1A

The car is released on a horizontal surface and moves forward in a straight line. It eventually comes to rest.

The velocity v of the car, at time t after its release, is given by the relationship

$$v = 0.0071t - 0.00025t^2$$

where v is measured in m s^{-1} and t is measured in s.

Using calculus methods:

- (a) determine the acceleration of the car 20.0 s after its release; 3
Space for working and answer

- (b) determine the distance travelled by the car 20.0 s after its release. 3
Space for working and answer



2. (a) A student places a radio-controlled car on a horizontal circular track, as shown in Figure 2A.

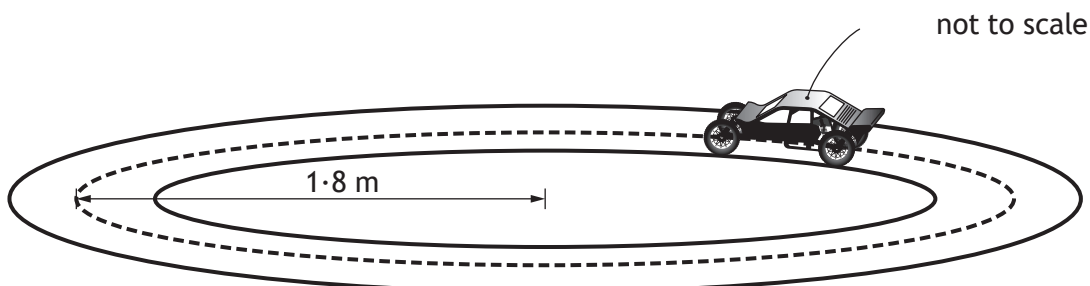

Figure 2A

The car travels around the track with a constant speed of 3.5 m s^{-1} . The track has a radius of 1.8 m .

- (i) Explain why the car is accelerating, even though it is travelling at a constant speed.

1

- (ii) Calculate the radial acceleration of the car.
Space for working and answer

3



2. (a) (continued)

(iii) The car has a mass of 0.431 kg .

The student now increases the speed of the car to 5.5 m s^{-1} .

The total radial friction between the car and the track has a maximum value of 6.4 N .

Show by calculation that the car cannot continue to travel in a circular path.

3

Space for working and answer

[Turn over



* X 7 5 7 7 7 0 1 0 5 *

2. (continued)

- (b) The car is now placed on a track, which includes a raised section. This is shown in Figure 2B.

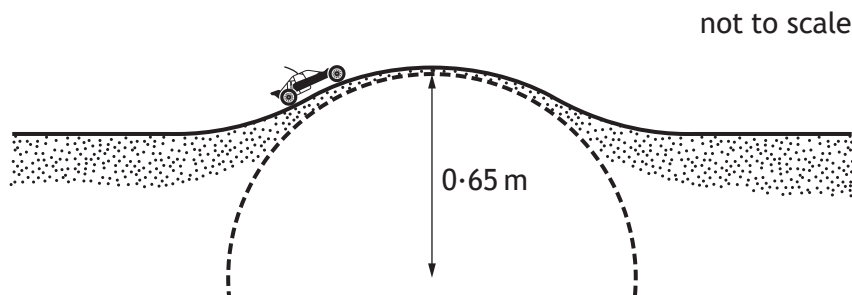

Figure 2B

The raised section of the track can be considered as the arc of a circle, which has radius r of 0.65 m.

- (i) The car will lose contact with the raised section of track if its speed is greater than v_{max} .

Show that v_{max} is given by the relationship

$$v_{max} = \sqrt{gr}$$

2

- (ii) Calculate the maximum speed v_{max} at which the car can cross the raised section without losing contact with the track.

2

Space for working and answer



* X 7 5 7 7 7 0 1 0 6 *

2. (b) (continued)

- (iii) A second car, with a smaller mass than the first car, approaches the raised section at the same speed as calculated in (b)(ii).

State whether the second car will lose contact with the track as it crosses the raised section.

Justify your answer in terms of forces acting on the car.

2

[Turn over



* X 7 5 7 7 7 0 1 0 7 *

3. Wheels on road vehicles can vibrate if the wheel is not 'balanced'. Garages can check that each wheel is balanced using a wheel balancing machine, as shown in Figure 3A.

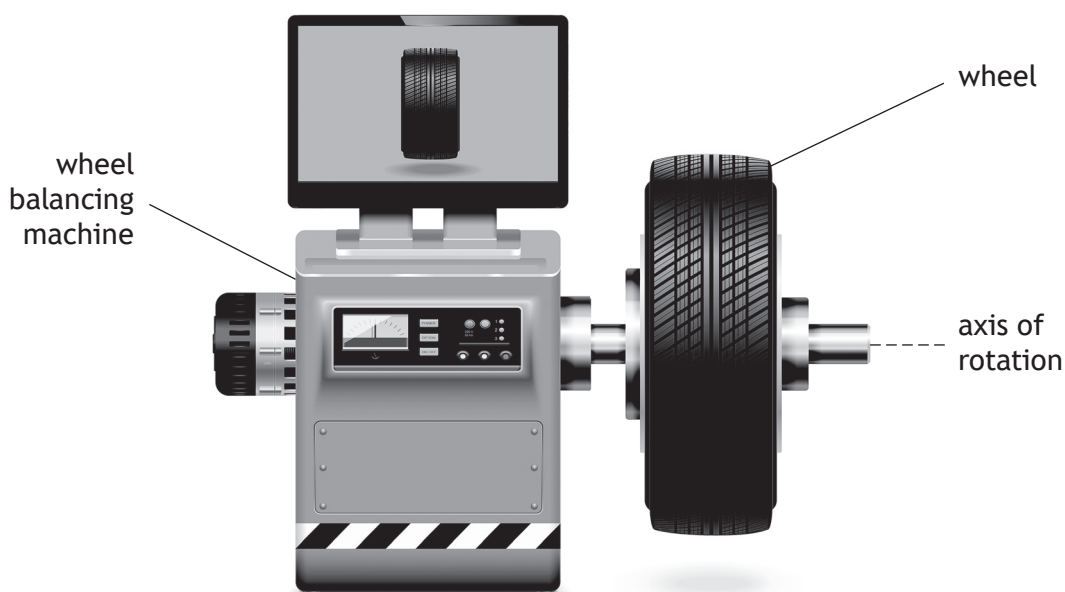

Figure 3A

The wheel is rotated about its axis by the wheel balancing machine.

The angular velocity of the wheel increases uniformly from rest with an angular acceleration of 6.7 rad s^{-2} .

- (a) The wheel reaches its maximum angular velocity after 3.9 s .

Show that its maximum angular velocity is 26 rad s^{-1} .

2

Space for working and answer



* X 7 5 7 7 7 0 1 0 8 *

3. (continued)

(b) After 3.9 s, the rotational kinetic energy of the wheel is 430 J.

Calculate the moment of inertia of the wheel.

3

Space for working and answer

(c) A brake is applied which brings the wheel uniformly to rest from its maximum velocity.

The wheel completes 14 revolutions during the braking process.

(i) Calculate the angular acceleration of the wheel during the braking process.

4

Space for working and answer

(ii) Calculate the braking torque applied by the wheel balancing machine.

3

Space for working and answer



* X 7 5 7 7 7 0 1 0 9 *

4. Astronomers have discovered another solar system in our galaxy. The main sequence star, HD 69830, lies at the centre of this solar system. This solar system also includes three exoplanets, b, c, and d and an asteroid belt. This solar system is shown in Figure 4A.

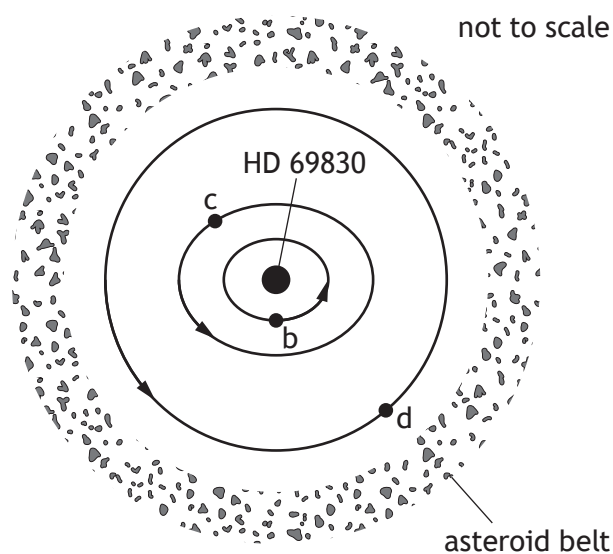

Figure 4A

- (a) The orbit of exoplanet d can be considered circular.
 To a reasonable approximation the centripetal force on exoplanet d is provided by the gravitational attraction of star HD 69830.
- (i) Show that, for a circular orbit of radius r , the period T of a planet about a parent star of mass M , is given by

$$T^2 = \frac{4\pi^2}{GM} r^3$$

3



4. (a) (continued)

(ii) Some information about this solar system is shown in the table below.

<i>Exoplanet</i>	<i>Type of orbit</i>	<i>Mass in Earth masses</i>	<i>Mean orbital radius in Astronomical Units (AU)</i>	<i>Orbital period In Earth days</i>
b	Elliptical	10.2	-	8.67
c	Elliptical	11.8	0.186	-
d	Circular	18.1	0.63	197

Determine the mass, in kg, of star HD 69830.

3

Space for working and answer

(b) Two asteroids collide at a distance of 1.58×10^{11} m from the centre of the star HD 69830. As a result of this collision, one of the asteroids escapes from this solar system.

Calculate the minimum speed which this asteroid must have immediately after the collision, in order to escape from this solar system.

3

Space for working and answer



* X 7 5 7 7 7 0 1 1 1 *

5. (a) Explain what is meant by the term *Schwarzschild radius*.

1

(b) (i) Calculate the Schwarzschild radius of the Sun.

3

Space for working and answer

(ii) Explain, with reference to its radius, why the Sun is not a black hole.

1

(c) The point of closest approach of a planet to the Sun is called the perihelion of the planet. The perihelion of Mercury rotates slowly around the Sun, as shown in Figure 5A.

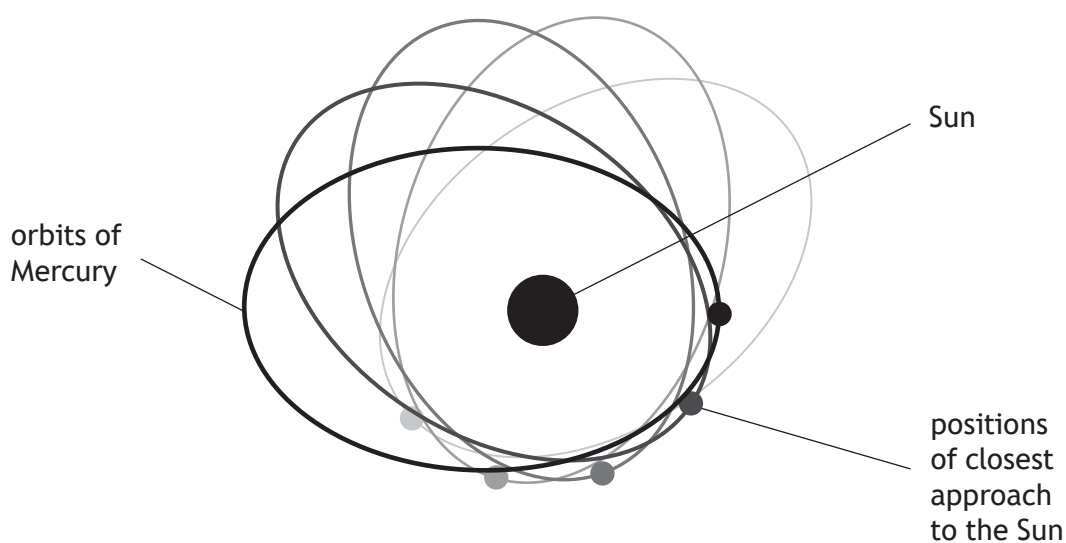

Figure 5A



* X 7 5 7 7 7 0 1 1 2 *

5. (c) (continued)

This rotation of the perihelion is referred to as the precession of Mercury, and is due to the curvature of spacetime. This causes an angular change in the perihelion of Mercury.

The angular change **per orbit** is calculated using the relationship

$$\phi = 3\pi \frac{r_s}{a(1-e^2)}$$

where:

ϕ is the angular change **per orbit**, in radians;

r_s is the Schwarzschild radius of the Sun, in metres;

a is the semi-major axis of the orbit, for Mercury $a = 5.805 \times 10^{10}$ m;

e is the eccentricity of the orbit, for Mercury $e = 0.206$.

Mercury completes **four** orbits of the Sun in one Earth year.

Determine the angular change in the perihelion of Mercury **after one Earth year**.

3

Space for working and answer



MARKS

DO NOT
WRITE IN
THIS
MARGIN

6. Bellatrix and Acrab are two stars which are similar in size. However, the apparent brightness of each is different.

Use your knowledge of stellar physics to comment on why there is a difference in the apparent brightness of the two stars.

3



* X 7 5 7 7 7 0 1 1 4 *

[Turn over for next question

DO NOT WRITE ON THIS PAGE



* X 7 5 7 7 7 0 1 1 5 *

7. In a crystal lattice, atoms are arranged in planes with a small gap between each plane.

Neutron diffraction is a process which allows investigation of the structure of crystal lattices.

In this process there are three stages:
neutrons are accelerated;
the neutrons pass through the crystal lattice;
an interference pattern is produced.

- (a) (i) In this process, neutrons exhibit wave-particle duality.

Identify the stage of the process which provides evidence for particle-like behaviour of neutrons.

1

- (ii) Neutrons, each with a measured momentum of $1.29 \times 10^{-23} \text{ kg m s}^{-1}$ produce an observable interference pattern from one type of crystal lattice.

Calculate the wavelength of a neutron travelling with this momentum.

3

Space for working and answer

- (iii) Explain the implication of the Heisenberg uncertainty principle for the precision of these experimental measurements.

1



* X 7 5 7 7 7 0 1 1 6 *

7. (a) (continued)

- (iv) The momentum of a neutron is measured to be $1.29 \times 10^{-23} \text{ kg m s}^{-1}$ with a precision of $\pm 3.0\%$.

Determine the minimum **absolute** uncertainty in the position Δx_{min} of this neutron.

4

Space for working and answer

- (b) Some of the neutrons used to investigate the structure of crystal lattices will not produce an observed interference pattern. This may be due to a large uncertainty in their momentum.

Explain why a large uncertainty in their momentum would result in these neutrons being unsuitable for this diffraction process.

2



* X 7 5 7 7 7 0 1 1 7 *

8. (a) Inside the core of stars like the Sun, hydrogen nuclei fuse together to form heavier nuclei.

(i) State the region of the Hertzsprung-Russell diagram in which stars like the Sun are located. 1

(ii) One type of fusion reaction is known as the proton-proton chain and is described below.

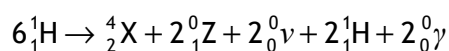

Identify the particles indicated by the letters X and Z. 2

(b) High energy charged particles are ejected from the Sun.

State the name given to the constant stream of charged particles which the Sun ejects. 1



* X 7 5 7 7 7 0 1 1 8 *

8. (continued)

MARKS
DO NOT
WRITE IN
THIS
MARGIN

- (c) The stream of particles being ejected from the Sun produces an outward pressure. This outward pressure depends on the number of particles being ejected from the Sun and the speed of these particles.

The pressure at a distance of one astronomical unit (AU) from the Sun is given by the relationship

$$p = 1.6726 \times 10^{-6} \times n \times v^2$$

where:

p is the pressure in nanopascals;

n is the number of particles per cubic centimetre;

v is the speed of particles in kilometres per second.

- (i) On one occasion, a pressure of 9.56×10^{-10} Pa was recorded when the particle speed was measured to be $6.02 \times 10^5 \text{ m s}^{-1}$.

Calculate the number of particles per cubic centimetre.

2

Space for working and answer

- (ii) The pressure decreases as the particles stream further from the Sun.

This is because the number of particles per cubic centimetre decreases and the kinetic energy of the particles decreases.

- (A) Explain why the number of particles per cubic centimetre decreases as the particles stream further from the Sun.

1

- (B) Explain why the kinetic energy of the particles decreases as the particles stream further from the Sun.

1



* X 7 5 7 7 7 0 1 1 9 *

8. (continued)

- (d) When the charged particles approach the Earth, the magnetic field of the Earth causes them to follow a helical path, as shown in Figure 8A.

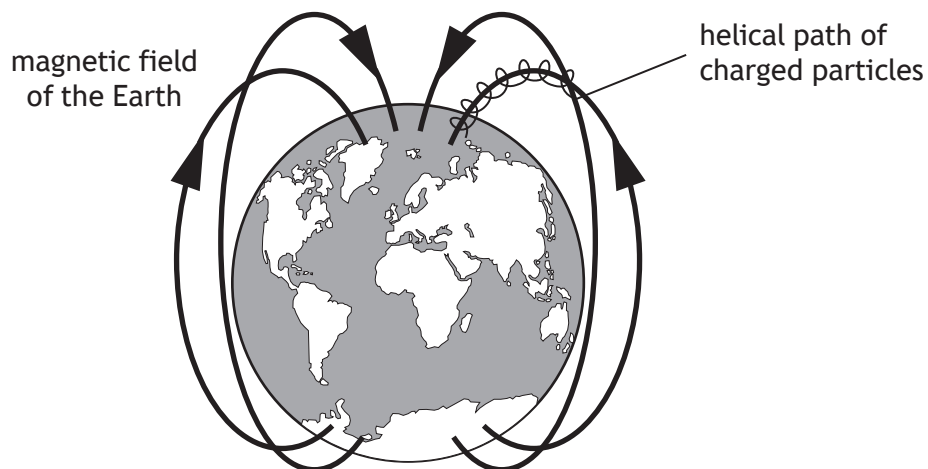

Figure 8A

Explain why the charged particles follow a helical path.

2



[Turn over for next question

DO NOT WRITE ON THIS PAGE



* X 7 5 7 7 7 0 1 2 1 *

9. A ball-bearing is released from height h on a smooth curved track, as shown in Figure 9A.
- The ball-bearing oscillates on the track about position P.
- The motion of the ball-bearing can be modelled as Simple Harmonic Motion (SHM).

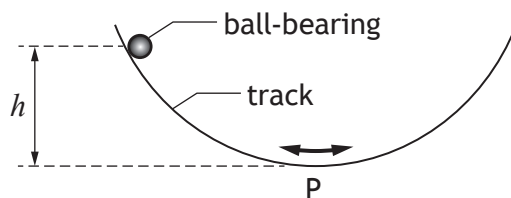

Figure 9A

- (a) The ball-bearing makes 1.5 oscillations in 2.5 s.
- (i) Show that the angular frequency of the ball-bearing is 3.8 rad s^{-1} . 2
Space for working and answer
- (ii) The horizontal displacement x of the ball-bearing from position P at time t can be predicted using the relationship
- $$x = -0.2\cos(3.8t)$$
- Using calculus methods, show that this relationship is consistent with SHM. 3



9. (a) (continued)

- (iii) Determine the maximum speed of the ball-bearing during its motion.

3

Space for working and answer

- (iv) Determine the height h from which the ball bearing was released.

3

Space for working and answer



* X 7 5 7 7 7 0 1 2 3 *

9. (continued)

MARKS
DO NOT
WRITE IN
THIS
MARGIN

- (b) In practice, the maximum horizontal displacement of the ball-bearing decreases with time.

A graph showing the variation in the horizontal displacement of the ball-bearing from position P with time is shown in Figure 9B.

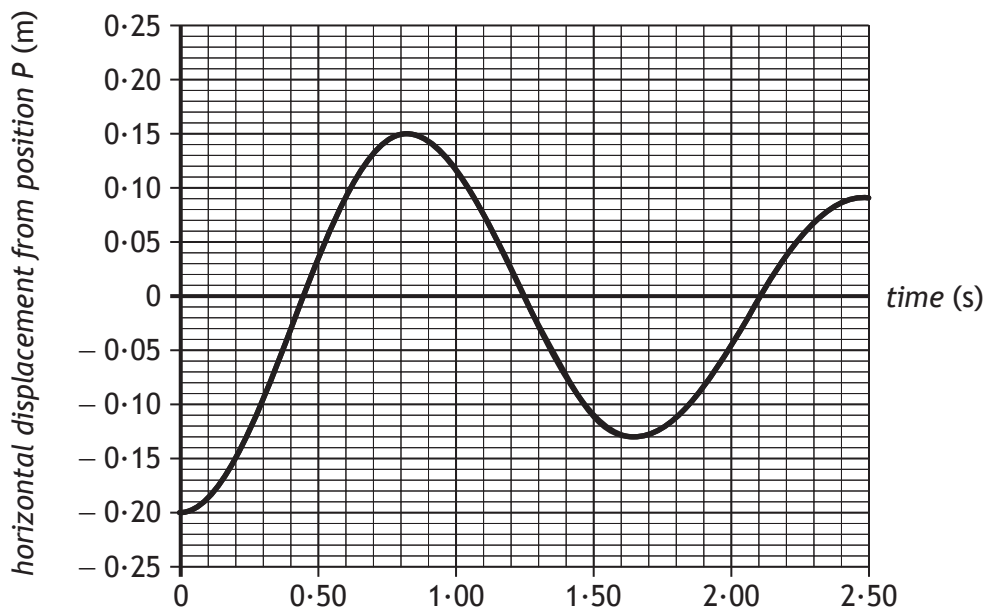

Figure 9B

Sketch a graph showing how the **vertical** displacement of the ball-bearing from position P changes over the same time period.

Numerical values are not required on either axis.

2



[Turn over for next question

DO NOT WRITE ON THIS PAGE



* X 7 5 7 7 7 0 1 2 5 *

10. An electromagnetic wave is travelling along an optical fibre. Inside the fibre the electric field vectors oscillate, as shown in Figure 10A.

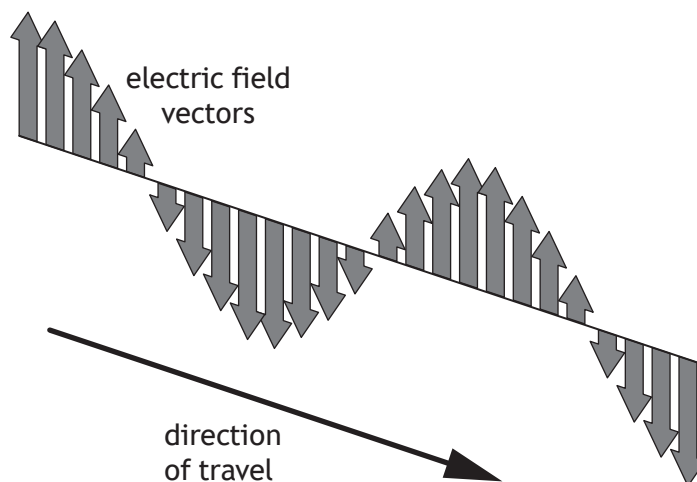

Figure 10A

The direction of travel of the wave is taken to be the x -direction.

The magnitude of the electric field vector E at any point x and time t is given by the relationship

$$E = 12 \times 10^{-6} \sin 2\pi \left(1.31 \times 10^{14} t - \frac{x}{1.55 \times 10^{-6}} \right)$$

- (a) (i) Two points, A and B, along the wave are separated by a distance of $4.25 \times 10^{-7} \text{ m}$ in the x -direction.

Calculate the phase difference between points A and B.

3

Space for working and answer



* X 7 5 7 7 7 0 1 2 6 *

10. (a) (continued)

- (ii) Another two points on the wave, P and Q, have a phase difference of π radians.

State how the direction of the electric field vector at point P compares to the direction of the electric field vector at point Q.

1

- (b) (i) Show that the speed of the electromagnetic wave in this optical fibre is $2.03 \times 10^8 \text{ m s}^{-1}$.

2

Space for working and answer

- (ii) The speed v_m of an electromagnetic wave in a medium is given by the relationship

$$v_m = \frac{1}{\sqrt{\epsilon_m \mu_m}}$$

The permeability μ_m of the optical fibre material can be considered to be equal to the permeability of free space.

By considering the speed of the electromagnetic wave in this fibre, determine the permittivity ϵ_m of the optical fibre material.

2

Space for working and answer



* X 7 5 7 7 7 0 1 2 7 *

11. A thin air wedge is formed between two glass plates of length 75 mm, which are in contact at one end and separated by a thin metal wire at the other end.

Figure 11A shows sodium light being reflected down onto the air wedge.

A travelling microscope is used to view the resulting interference pattern.

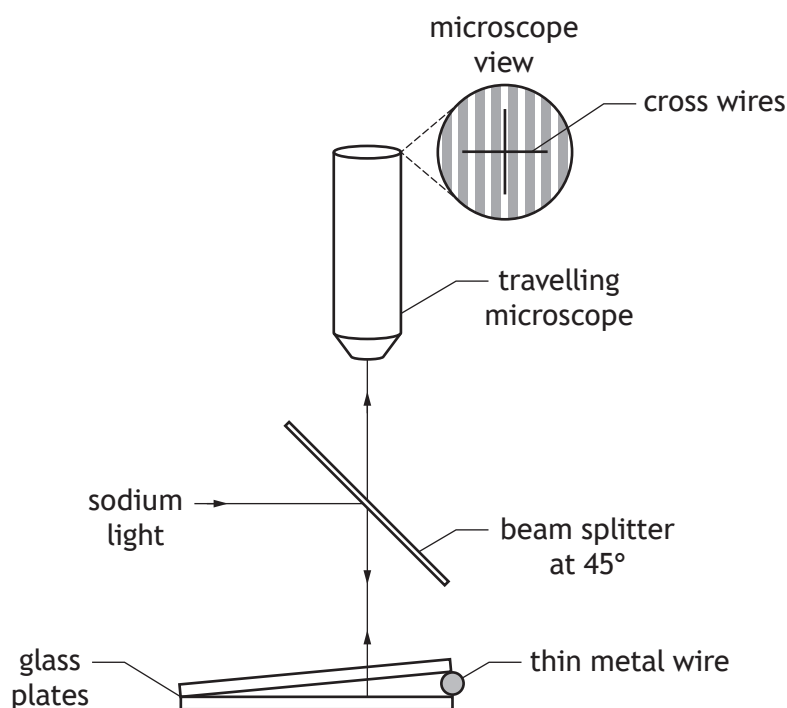

Figure 11A

A student observes the image shown in Figure 11B.

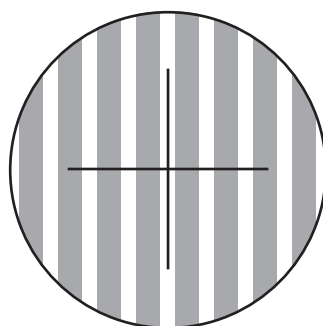

Figure 11B

The student aligns the cross-hairs to a bright fringe and then moves the travelling microscope until 20 further bright fringes have passed through the cross-hairs and notes that the travelling microscope has moved a distance of 9.8×10^{-4} m.

The student uses this data to determine the thickness of the thin metal wire between the glass plates.



* X 7 5 7 7 7 0 1 2 8 *

11. (continued)

MARKS
DO NOT
WRITE IN
THIS
MARGIN

(a) State whether the interference pattern is produced by division of amplitude or by division of wavefront.

1

(b) Determine the diameter of the thin metal wire.

4

Space for working and answer

(c) By measuring multiple fringe separations rather than just one, the student states that they have more confidence in the value of diameter of the wire which was obtained.

Suggest one reason why the student's statement is correct.

1

(d) A current is now passed through the thin metal wire and its temperature increases.

The fringes are observed to get closer together.

Suggest a possible explanation for this observation.

2



* X 7 5 7 7 7 0 1 2 9 *

12. A student is observing the effect of passing light through polarising filters. Two polarising filters, the polariser and the analyser, are placed between a lamp and the student as shown in Figure 12A. The polariser is held in a fixed position, and the analyser can be rotated. Angle θ is the angle between the transmission axes of the two filters.

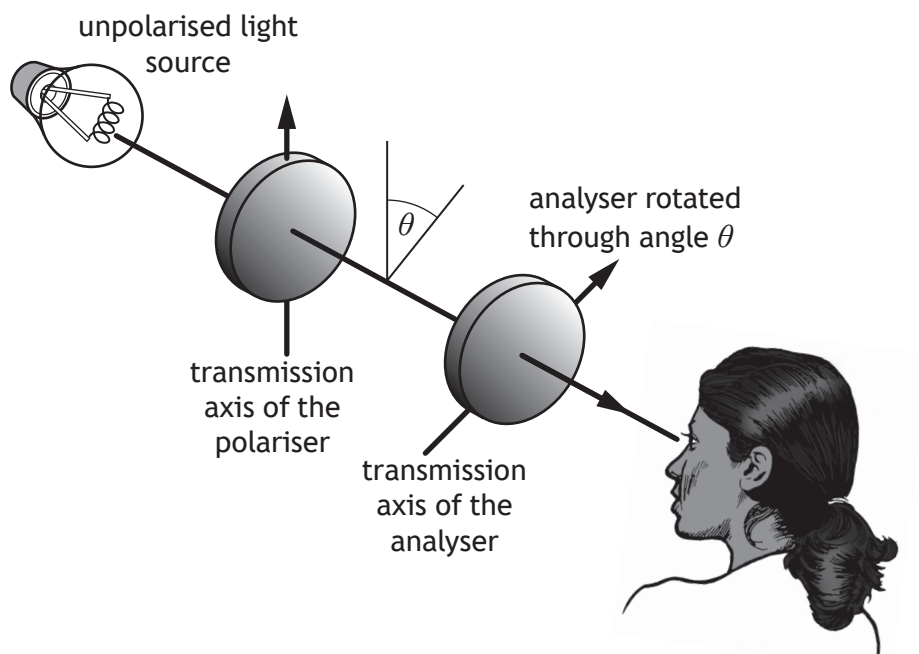

Figure 12A

When the transmission axes of the polariser and the analyser are parallel, θ is 0° and the student observes bright light from the lamp.

- (a) (i) Describe, in terms of brightness, what the student observes as the analyser is slowly rotated from 0° to 180° . 2
- (ii) The polariser is now removed. Describe, in terms of brightness, what the student observes as the analyser is again slowly rotated from 0° to 180° . 1



12. (continued)

- (b) Sunlight reflected from a wet road can cause glare, which is hazardous for drivers. This is shown in Figure 12B

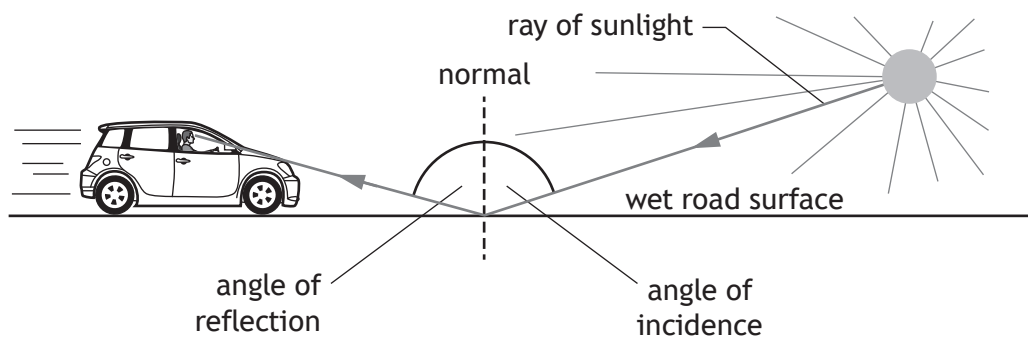

Figure 12B

Reflected sunlight is polarised when the light is incident on the wet road surface at the Brewster angle.

- (i) Calculate the Brewster angle for light reflected from water. 3

Space for working and answer

- (ii) A driver is wearing polarising sunglasses.

Explain how wearing polarising sunglasses rather than non-polarising sunglasses will reduce the glare experienced by the driver. 1



* X 7 5 7 7 7 0 1 3 1 *

13. (a) State what is meant by *electric field strength*.

(b) Two identical spheres, each with a charge of $+22 \text{ nC}$, are suspended from point P by two equal lengths of light insulating thread.

The spheres repel and come to rest in the positions shown in Figure 13A.

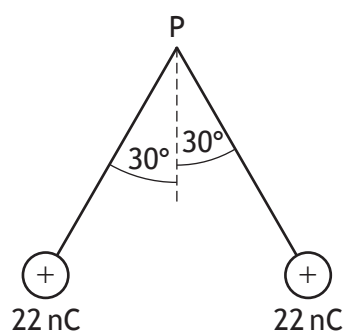

Figure 13A

(i) Each sphere has a weight of $9.80 \times 10^{-4} \text{ N}$.

By considering the forces acting on one of the spheres, show that the electric force between the charges is $5.66 \times 10^{-4} \text{ N}$.

Space for working and answer



13. (b) (continued)

- (ii) By considering the electric force between the charges, calculate the distance between the centres of the spheres.

3

Space for working and answer

- (iii) Calculate the electrical potential at point P due to both charged spheres.

5

Space for working and answer



* X 7 5 7 7 7 0 1 3 3 *

14. A student carries out an experiment to determine the charge to mass ratio of the electron.

The apparatus is set up as shown in Figure 14A.

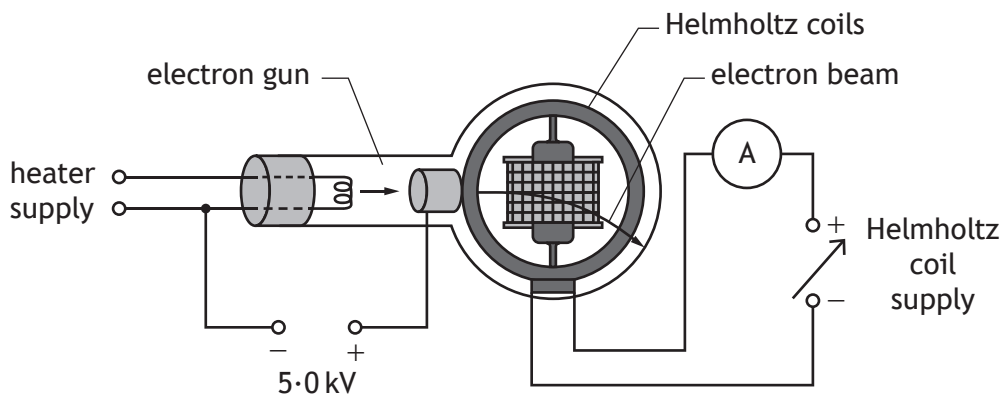

Figure 14A

An electron beam is produced using an electron gun connected to a 5.0 kV supply. A current I in the Helmholtz coils produces a uniform magnetic field.

The electron beam enters the magnetic field.

The path of the electron beam between points O and P can be considered to be an arc of a circle of constant radius r . This is shown in Figure 14B.

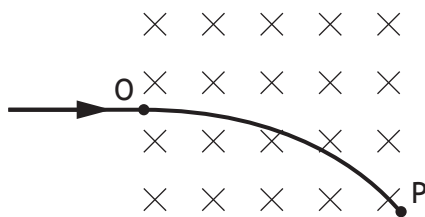

Figure 14B

The student records the following measurements:

Electron gun supply voltage, V	5.0 kV ($\pm 10\%$)
Current in the Helmholtz coils, I	0.22 A ($\pm 5\%$)
Radius of curvature of the path of the electron beam between O and P, r	0.28 m ($\pm 6\%$)



* X 7 5 7 7 7 0 1 3 4 *

14. (continued)

MARKS
DO NOT
WRITE IN
THIS
MARGIN

- (a) The manufacturer's instruction sheet states that the magnetic field strength B at the centre of the apparatus is given by

$$B = 4.20 \times 10^{-3} \times I$$

Calculate the magnitude of the magnetic field strength in the centre of the apparatus.

1

Space for working and answer

- (b) The charge to mass ratio of the electron is calculated using the following relationship

$$\frac{q}{m} = \frac{2V}{B^2 r^2}$$

- (i) Using the measurements recorded by the student, calculate the charge to mass ratio of the electron.

2

Space for working and answer

- (ii) Determine the absolute uncertainty in the charge to mass ratio of the electron.

4

Space for working and answer



* X 7 5 7 7 7 0 1 3 5 *

14. (continued)

- (c) A second student uses the same equipment to find the charge to mass ratio of the electron and analyses their measurements differently.

The current in the Helmholtz coils is varied to give a range of values for magnetic field strength. This produces a corresponding range of measurements of the radius of curvature.

The student then draws a graph and uses the gradient of the line of best fit to determine the charge to mass ratio of the electron.

Suggest which quantities the student chose for the axes of the graph.

1



* X 7 5 7 7 7 0 1 3 6 *

14. (continued)

- (d) The graphical method of analysis used by the second student should give a more reliable value for the charge to mass ratio of the electron than the value obtained by the first student.

Use your knowledge of experimental physics to explain why this is the case.

3



* X 7 5 7 7 7 0 1 3 7 *

15. A defibrillator is a device that gives an electric shock to a person whose heart has stopped beating normally.

This is shown in Figure 15A.

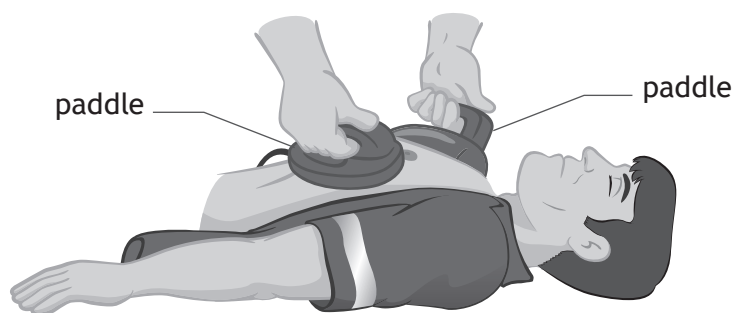

Figure 15A

Two paddles are initially placed in contact with the patient's chest. A simplified defibrillator circuit is shown in Figure 15B.

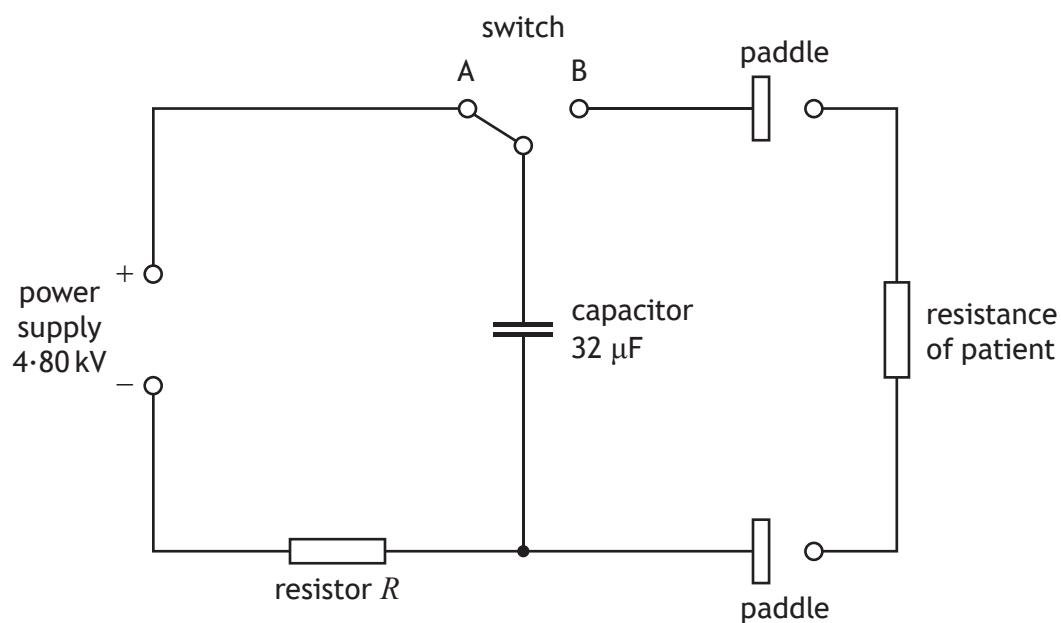

Figure 15B

When the switch is in position A, the capacitor is charged until there is a large potential difference across the capacitor.



* X 7 5 7 7 7 0 1 3 8 *

15. (continued)

- (a) The capacitor can be considered to be fully charged after 5 time constants.
The time taken for the capacitor to be considered to be fully charged is 10.0 s.

Determine the resistance of resistor R .

3

Space for working and answer

- (b) During a test, an $80.0\ \Omega$ resistor is used in place of the patient.
The switch is moved to position B, and the capacitor discharges through the $80.0\ \Omega$ resistor.

The initial discharge current is 60 A.

The current in the resistor will fall to half of its initial value after 0.7 time constants.

Show that the current falls to 30 A in 1.8 ms.

2

Space for working and answer



* X 7 5 7 7 7 0 1 3 9 *

15. (continued)

MARKS

DO NOT
WRITE IN
THIS
MARGIN

- (c) In practice a current greater than 30A is required for a minimum of 5.0 ms to force the heart of a patient to beat normally.

An inductor, of negligible resistance, is included in the circuit to increase the discharge time of the capacitor to a minimum of 5.0 ms.

This is shown in Figure 15C.

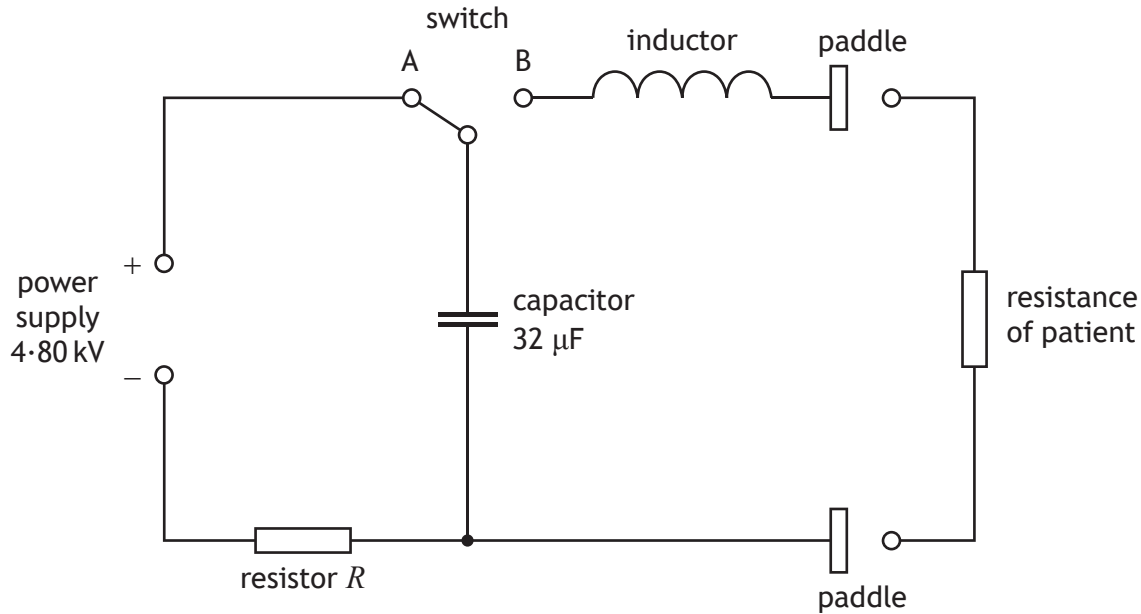

Figure 15C

- (i) The inductor has an inductance of 50.3 mH.

The capacitor is again fully charged. The switch is then moved to position B.

Calculate the rate of change of current at the instant the switch is moved to position B.

3

Space for working and answer



* X 7 5 7 7 7 0 1 4 0 *

15. (c) (continued)

- (ii) It would be possible to increase the discharge time of the capacitor with an additional resistor connected in the circuit in place of the inductor. However, the use of an additional resistor would mean that maximum energy was not delivered to the patient.

Explain why it is more effective to use an inductor, rather than an additional resistor, to ensure that maximum energy is delivered to the patient.

2

[END OF QUESTION PAPER]



* X 7 5 7 7 7 0 1 4 1 *

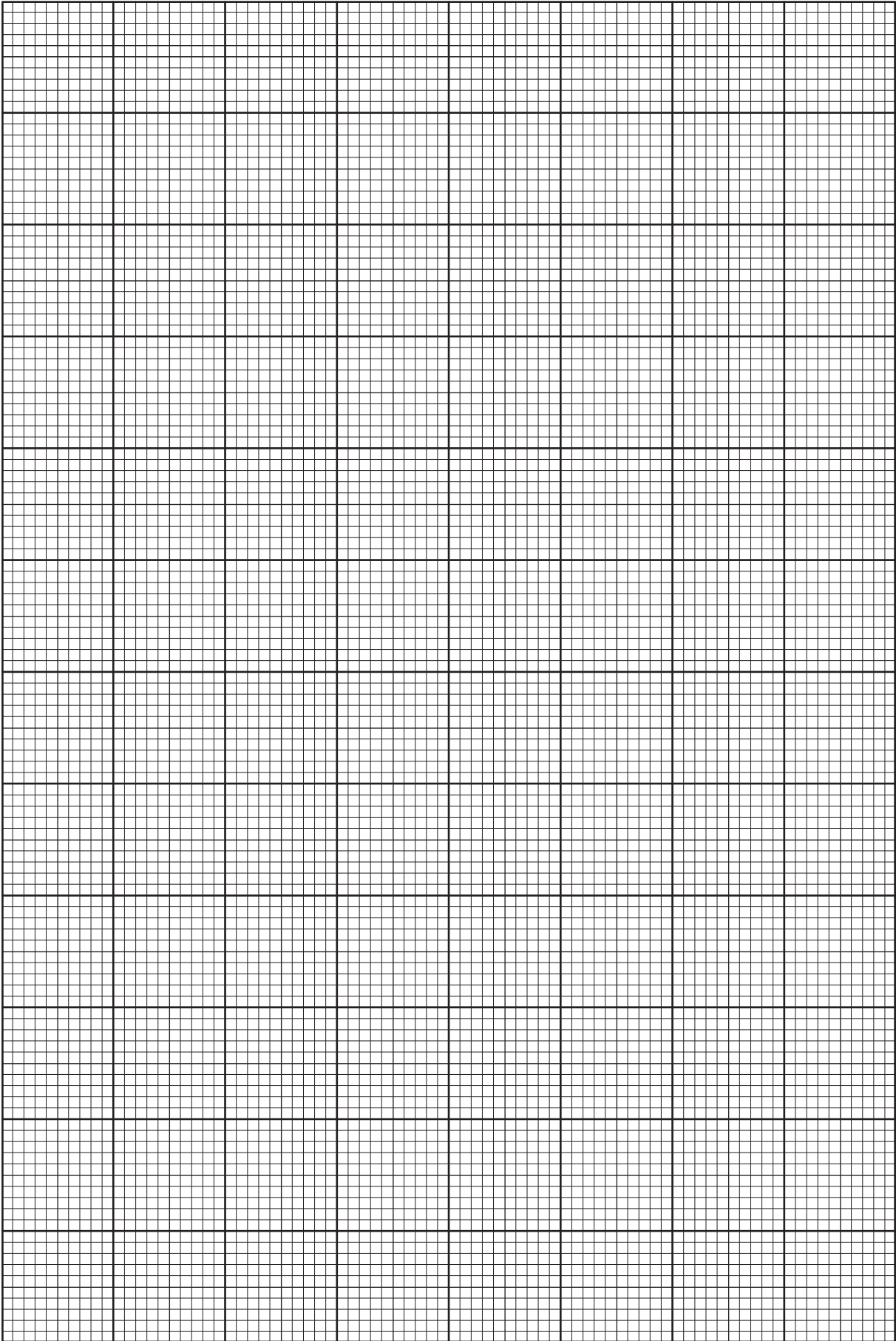

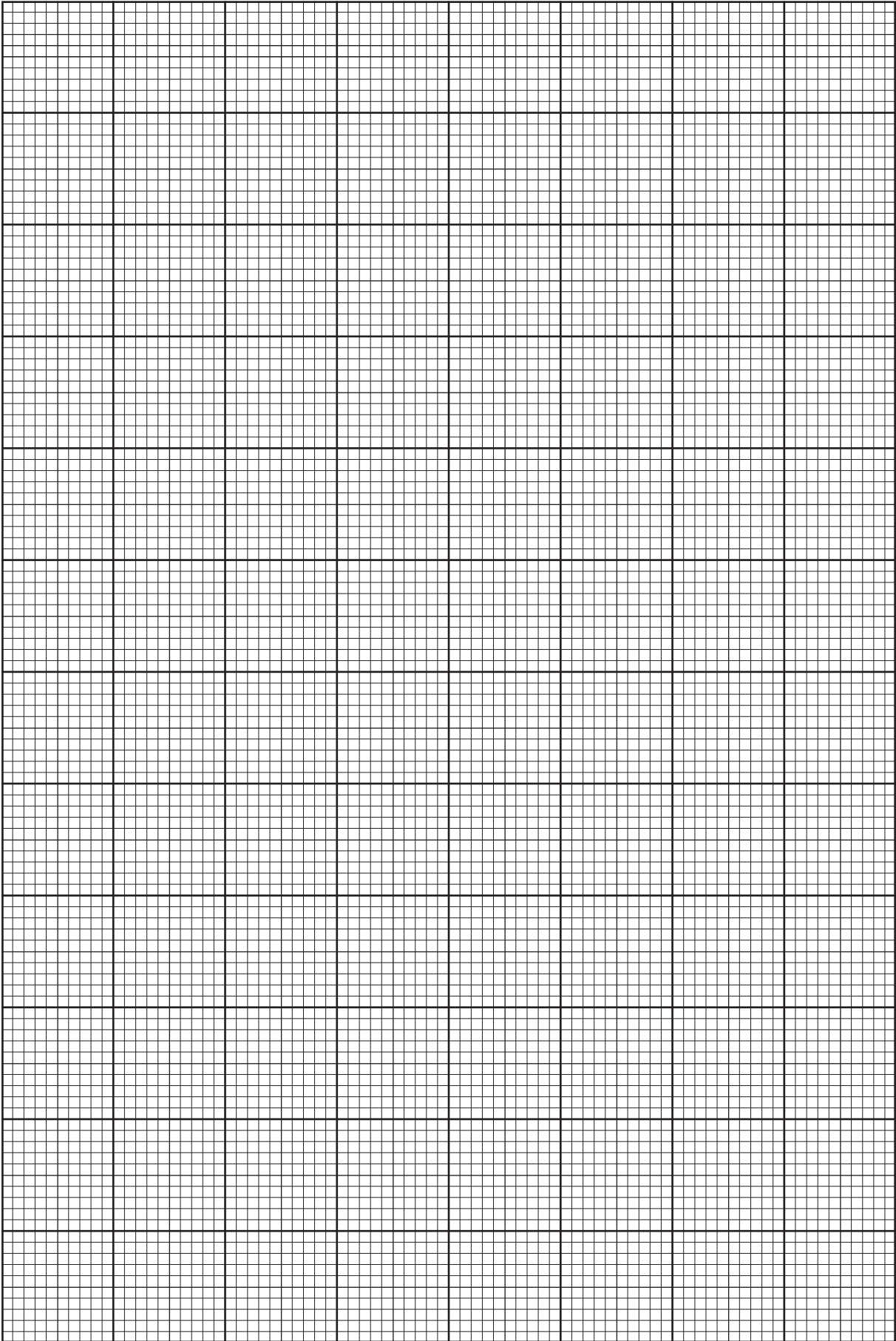

* X 7 5 7 7 7 0 1 4 3 *

MARKS

DO NOT
WRITE IN
THIS
MARGIN

ADDITIONAL SPACE FOR ANSWERS AND ROUGH WORK



* X 7 5 7 7 7 0 1 4 4 *

MARKS

DO NOT
WRITE IN
THIS
MARGIN

ADDITIONAL SPACE FOR ANSWERS AND ROUGH WORK



* X 7 5 7 7 7 0 1 4 5 *

MARKS

DO NOT
WRITE IN
THIS
MARGIN

ADDITIONAL SPACE FOR ANSWERS AND ROUGH WORK



* X 7 5 7 7 7 0 1 4 6 *

[BLANK PAGE]

DO NOT WRITE ON THIS PAGE



* X 7 5 7 7 7 0 1 4 7 *

ACKNOWLEDGEMENTS

Question 1 – Figure 1A – CG Stocker/Shutterstock.com

Question 3 – Figure 3A – dashadima/Shutterstock.com

Question 15 – Figure 15A – Luciano Cosmo/shutterstock.com



* X 7 5 7 7 7 0 1 4 8 *