

FOR OFFICIAL USE



National
Qualifications
2019

Mark

X757/77/01

Physics

WEDNESDAY, 15 MAY

9:00 AM – 11:30 AM



* X 7 5 7 7 7 0 1 *

Fill in these boxes and read what is printed below.

Full name of centre

Town

Forename(s)

Surname

Number of seat

Date of birth

Day

Month

Year

Scottish candidate number

Total marks — 140

Attempt ALL questions.

Reference may be made to the Physics Relationships Sheet X757/77/11 and the Data Sheet on page 02.

Write your answers clearly in the spaces provided in this booklet. Additional space for answers and rough work is provided at the end of this booklet. If you use this space you must clearly identify the question number you are attempting. Any rough work must be written in this booklet. You should score through your rough work when you have written your final copy.

Care should be taken to give an appropriate number of significant figures in the final answers to calculations.

Use **blue** or **black** ink.

Before leaving the examination room you must give this booklet to the Invigilator; if you do not, you may lose all the marks for this paper.



* X 7 5 7 7 7 0 1 0 1 *

DATA SHEET

COMMON PHYSICAL QUANTITIES

Quantity	Symbol	Value	Quantity	Symbol	Value
Gravitational acceleration on Earth	g	9.8 m s^{-2}	Mass of electron	m_e	$9.11 \times 10^{-31} \text{ kg}$
Radius of Earth	R_E	$6.4 \times 10^6 \text{ m}$	Charge on electron	e	$-1.60 \times 10^{-19} \text{ C}$
Mass of Earth	M_E	$6.0 \times 10^{24} \text{ kg}$	Mass of neutron	m_n	$1.675 \times 10^{-27} \text{ kg}$
Mass of Jupiter	M_J	$1.90 \times 10^{27} \text{ kg}$	Mass of proton	m_p	$1.673 \times 10^{-27} \text{ kg}$
Radius of Jupiter	R_J	$7.15 \times 10^7 \text{ m}$	Mass of alpha particle	m_α	$6.645 \times 10^{-27} \text{ kg}$
Mean Radius of Jupiter Orbit		$7.79 \times 10^{11} \text{ m}$	Charge on alpha particle		$3.20 \times 10^{-19} \text{ C}$
Solar radius		$6.955 \times 10^8 \text{ m}$	Planck's constant	h	$6.63 \times 10^{-34} \text{ J s}$
Mass of Sun		$2.0 \times 10^{30} \text{ kg}$	Permittivity of free space	ϵ_0	$8.85 \times 10^{-12} \text{ F m}^{-1}$
1 AU		$1.5 \times 10^{11} \text{ m}$	Permeability of free space	μ_0	$4\pi \times 10^{-7} \text{ H m}^{-1}$
Stefan-Boltzmann constant	σ	$5.67 \times 10^{-8} \text{ W m}^{-2} \text{ K}^{-4}$	Speed of light in vacuum	c	$3.00 \times 10^8 \text{ m s}^{-1}$
Universal constant of gravitation	G	$6.67 \times 10^{-11} \text{ m}^3 \text{ kg}^{-1} \text{ s}^{-2}$	Speed of sound in air	v	$3.4 \times 10^2 \text{ m s}^{-1}$

REFRACTIVE INDICES

The refractive indices refer to sodium light of wavelength 589 nm and to substances at a temperature of 273 K.

Substance	Refractive index	Substance	Refractive index
Diamond	2.42	Glycerol	1.47
Glass	1.51	Water	1.33
Ice	1.31	Air	1.00
Perspex	1.49	Magnesium Fluoride	1.38

SPECTRAL LINES

Element	Wavelength/nm	Colour	Element	Wavelength/nm	Colour
Hydrogen	656	Red	Cadmium	644	Red
	486	Blue-green		509	Green
	434	Blue-violet		480	Blue
	410	Violet	<i>Lasers</i>		
	397	Ultraviolet	<i>Element</i>	<i>Wavelength/nm</i>	<i>Colour</i>
	389	Ultraviolet	Carbon dioxide	9550 } 10590 }	Infrared
Sodium	589	Yellow	Helium-neon	633	Red

PROPERTIES OF SELECTED MATERIALS

Substance	Density/ kg m^{-3}	Melting Point/ K	Boiling Point/ K	Specific Heat Capacity/ $\text{J kg}^{-1} \text{ K}^{-1}$	Specific Latent Heat of Fusion/ J kg^{-1}	Specific Latent Heat of Vaporisation/ J kg^{-1}
Aluminium	2.70×10^3	933	2623	9.02×10^2	3.95×10^5
Copper	8.96×10^3	1357	2853	3.86×10^2	2.05×10^5
Glass	2.60×10^3	1400	6.70×10^2
Ice	9.20×10^2	273	2.10×10^3	3.34×10^5
Glycerol	1.26×10^3	291	563	2.43×10^3	1.81×10^5	8.30×10^5
Methanol	7.91×10^2	175	338	2.52×10^3	9.9×10^4	1.12×10^6
Sea Water	1.02×10^3	264	377	3.93×10^3
Water	1.00×10^3	273	373	4.18×10^3	3.34×10^5	2.26×10^6
Air	1.29
Hydrogen	9.0×10^{-2}	14	20	1.43×10^4	4.50×10^5
Nitrogen	1.25	63	77	1.04×10^3	2.00×10^5
Oxygen	1.43	55	90	9.18×10^2	2.40×10^4

The gas densities refer to a temperature of 273 K and a pressure of $1.01 \times 10^5 \text{ Pa}$.



* X 7 5 7 7 7 0 1 0 2 *

Total marks — 140
Attempt ALL questions

1. A spacecraft accelerates from rest at time $t = 0$.

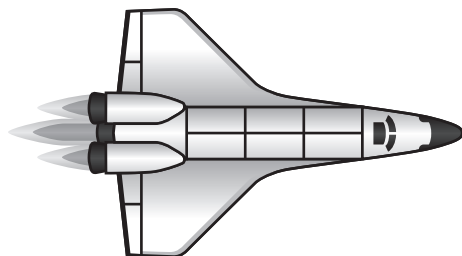

The velocity v of the spacecraft at time t is given by the relationship

$$v = 4.2t^2 + 1.6t$$

where v is measured in m s^{-1} and t is measured in s.

Using calculus methods

- (a) determine the time at which the acceleration of the spacecraft is 24 m s^{-2} **3**

Space for working and answer

- (b) determine the distance travelled by the spacecraft in this time. **3**

Space for working and answer



2. Riders on a theme park attraction sit in pods, which are suspended by wires. This is shown in Figure 2A.



Figure 2A

- (a) (i) During the ride, a pod travels at a constant speed of 8.8 m s^{-1} in a horizontal circle.

The radius of the circle is 7.6 m .

When occupied, the pod has a mass of 380 kg .

Calculate the centripetal force acting on the pod.

3

Space for working and answer

- (ii) State the direction of the centripetal force.

1



* X 7 5 7 7 7 0 1 0 4 *

2. (continued)

- (b) (i) Figure 2B shows a simplified model of a pod following a horizontal circular path. The pod is suspended from a fixed point by a cord.

On Figure 2B, show the forces acting on the pod as it travels at a constant speed in a horizontal circle.

You must name these forces and show their directions.

2

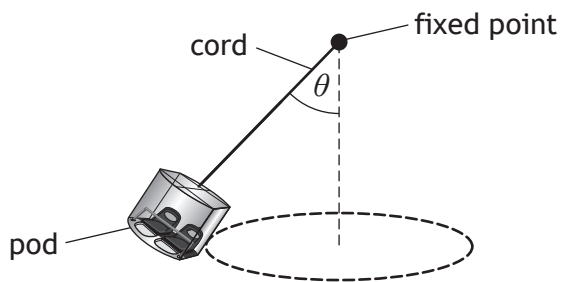

Figure 2B

- (ii) The speed of the pod decreases.

State the effect this has on the angle θ .

You must justify your answer in terms of the forces acting on the pod.

2



3. A gymnast, in a straight position, rotates around a high bar. This is shown in Figure 3A.

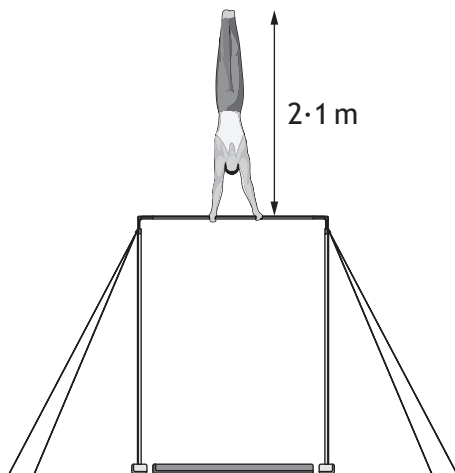

Figure 3A

The mass of the gymnast is 63 kg.

With arms extended, the total length of the gymnast is 2.1 m.

The gymnast is rotating with an angular velocity of 7.9 rad s^{-1} .

- (a) With arms extended, the gymnast can be approximated as a uniform rod.

Using this approximation, show that the moment of inertia of the gymnast around the bar is 93 kg m^2 .

2

Space for working and answer



* X 7 5 7 7 7 0 1 0 6 *

3. (continued)

- (b) The gymnast now makes a pike position, by bending at the waist. This is shown in Figure 3B.

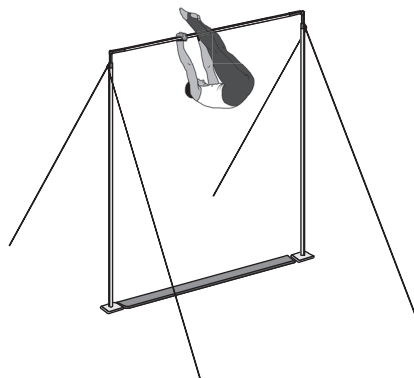

Figure 3B

This change of position causes the moment of inertia of the gymnast to decrease to 62 kg m^2 .

- (i) Explain why making a pike position results in a decrease in the moment of inertia of the gymnast.

1

- (ii) By considering the conservation of angular momentum, determine the angular velocity of the gymnast in the pike position.

3

Space for working and answer



* X 7 5 7 7 7 0 1 0 7 *

4. Passengers are sitting on a bus as it goes around a tight bend at speed.

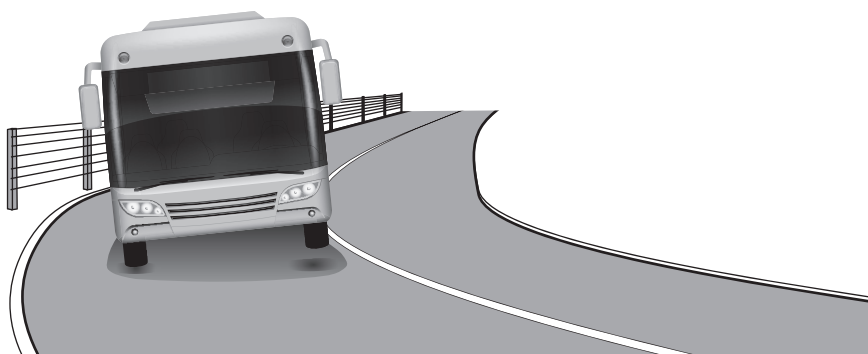

The following conversation is overheard between two of the passengers after the journey.

Passenger one: 'Did you feel that centrifugal force? It nearly tipped the bus over!'

Passenger two: 'There is no such thing as centrifugal force. It's centripetal force that gets the bus around the bend.'

Passenger one: 'There is centrifugal force, it depends on your frame of reference.'

Passenger two: 'No, centrifugal force is just imaginary.'

Use your knowledge of physics to comment on the overheard conversation.

3



* X 7 5 7 7 7 0 1 0 8 *

DO NOT
WRITE IN
THIS
MARGIN

4. (continued)



* X 7 5 7 7 7 0 1 0 9 *

5. Juno is a spacecraft with a mission to survey Jupiter.
 Juno is in an elliptical orbit around Jupiter.
 This is shown in Figure 5A.

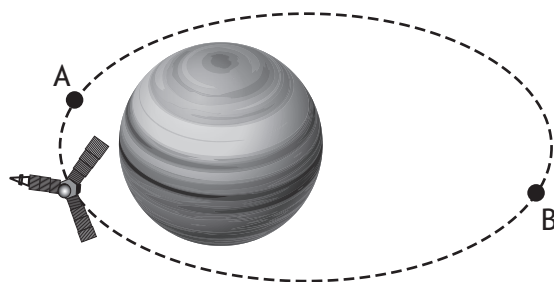

not to scale

Figure 5A

- (a) The gravitational potential at point A in the orbit of Juno is $-1.70 \times 10^9 \text{ J kg}^{-1}$.
 State what is meant by a *gravitational potential of $-1.70 \times 10^9 \text{ J kg}^{-1}$* . 1
- (b) At point B, Juno is $1.69 \times 10^8 \text{ m}$ from the centre of Jupiter.
 Calculate the gravitational potential at point B. 3
Space for working and answer



5. (continued)

- (c) The mass of Juno is 1.6×10^3 kg.

Determine the change in gravitational potential energy of Juno when it has moved from point A to point B.

4

Space for working and answer



* X 7 5 7 7 7 0 1 1 1 *

6. In 1915, Albert Einstein presented his general theory of relativity. The equivalence principle is a key part of this theory.

(a) State what is meant by *the equivalence principle*.

1

(b) Spacetime diagrams are used to show the world line of objects.

A spacetime diagram representing the world lines of two objects, P and Q, is shown in Figure 6A.

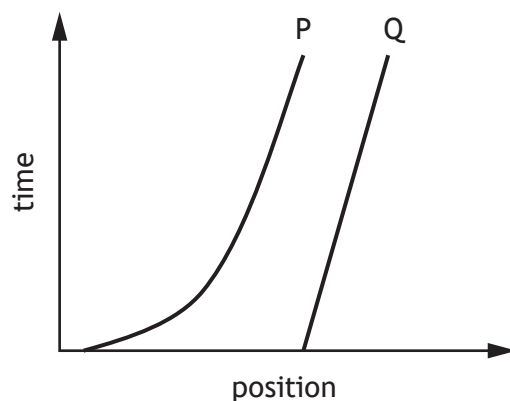

Figure 6A

(i) State which of these objects is accelerating.

1

(ii) On Figure 6A, draw a world line that would represent a stationary object.

1



6. (continued)

- (c) General relativity explains the spacetime curvature caused by a black hole. This curvature causes a ray of light to appear to be deflected. This is known as gravitational lensing.

The angle of deflection θ , in radians, is given by the relationship

$$\theta = \frac{4GM}{rc^2}$$

where

G is the universal constant of gravitation

M is the mass of the black hole

r is the distance between the black hole and the ray of light

c is the speed of light in a vacuum.

- (i) Imaging of the region around a black hole shows an angle of deflection of 0.0487 radians when a ray of light is 1.54×10^6 m from the black hole.

Determine the mass of the black hole.

2

Space for working and answer



* X 7 5 7 7 7 0 1 1 3 *

6. (c) (continued)

- (ii) Gravitational lensing causes the deflection of light rays from background stars that appear close to the edge of the Sun. This phenomenon can be observed during a total solar eclipse.

It can be shown that the angle of deflection θ , in radians, of a ray of light by a star of mass M is related to the Schwarzschild radius of the star and the distance r between the ray of light and the centre of the star.

$$\theta = \frac{2r_{\text{Schwarzschild}}}{r}$$

The Schwarzschild radius of the Sun is equal to 3.0×10^3 m.

- (A) Calculate the angle of deflection in radians of a ray of light that grazes the edge of the Sun.

2

Space for working and answer

- (B) On the axes below, sketch a graph showing the observed variation of the angle of deflection of a ray of light with its distance from the centre of the Sun.

2

Numerical values are not required on either axis.

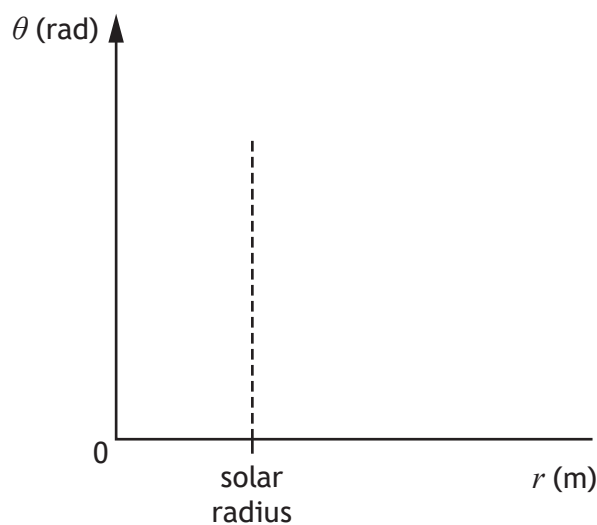

(An additional diagram, if required, can be found on page 46.)



[Turn over for next question

DO NOT WRITE ON THIS PAGE



* X 7 5 7 7 7 0 1 1 5 *

7. A Hertzsprung-Russell (H-R) diagram is shown in Figure 7A.

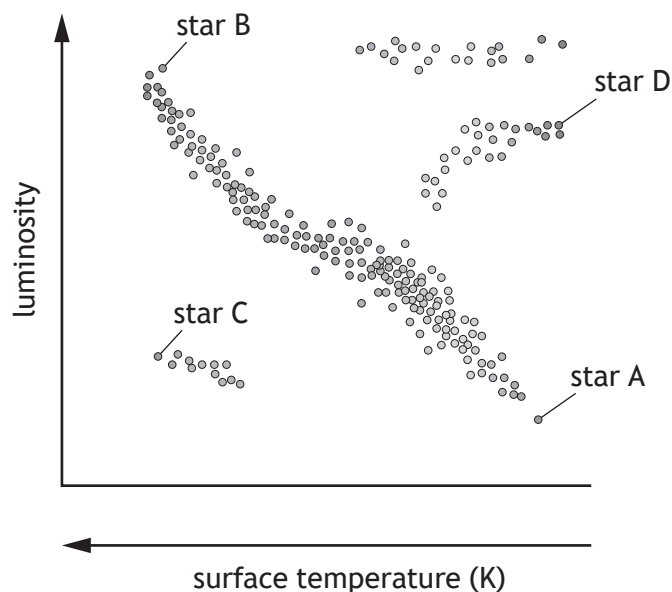

Figure 7A

(a) Stars are classified depending on their position on the H-R diagram.

(i) Four stars are labelled on the H-R diagram.

State which of these stars is a red giant.

1

(ii) At present the Sun is a main sequence star. It is predicted that the Sun will eventually become a red giant.

(A) State the change that will occur in the fusion reactions within the core of the Sun at the point when it leaves the main sequence.

1

(B) Explain, in terms of gravitational force and thermal pressure, why the diameter of the Sun will increase as it becomes a red giant.

1



7. (continued)

(b) Betelgeuse is a red supergiant star in the constellation Orion.

It is 6.1×10^{18} m from Earth and has an apparent brightness of $1.6 \times 10^{-7} \text{ W m}^{-2}$.

(i) Calculate the luminosity of Betelgeuse.

3

Space for working and answer

(ii) The radius of Betelgeuse is 8.3×10^{11} m.

Calculate the surface temperature of Betelgeuse.

3

Space for working and answer

(c) Ultimately, every main sequence star will become either a white dwarf, a neutron star or a black hole.

State the property of a star that determines which of these it will eventually become.

1



* X 7 5 7 7 7 0 1 1 7 *

8. Muons are created when cosmic rays enter the atmosphere of the Earth. This is shown in Figure 8A.

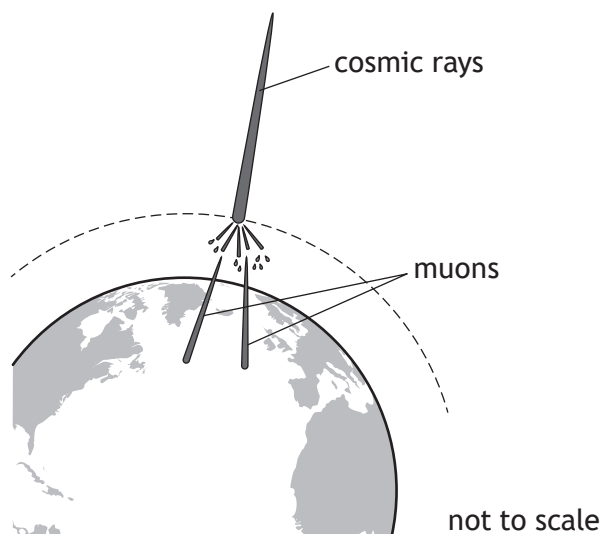

Figure 8A

To an observer on Earth the muons appear to have a lifetime of $8.5 \mu\text{s}$.

Instruments on Earth can detect muons and measure muon energy E .

The precision of the muon energy measurement is limited by the lifetime Δt of the muon.

- (a) By considering the Heisenberg uncertainty principle, calculate the minimum uncertainty in muon energy ΔE_{\min} .

3

Space for working and answer



8. (continued)

(b) Some muons, detected at sea level, have an average energy of 4.1×10^9 eV.

An instrument detects 10 000 such muons in one minute.

Determine the average total energy, in joules, measured per second.

3

Space for working and answer

(c) At sea level, these muons have an average momentum of 4.87×10^{-19} kg m s⁻¹.

By calculating the de Broglie wavelength of a muon with this momentum, explain why muons at sea level can be regarded as particles.

4

Space for working and answer



* X 7 5 7 7 7 0 1 1 9 *

9. An excerpt from a student's notes on fusion reactions is quoted below.

Electrostatic repulsion must be overcome before fusion can occur.

Two protons repel one another because of the electrostatic force between them.

If two protons can be brought close enough together, however, the electrostatic repulsion can be overcome by the quantum effect in which protons can tunnel through electrostatic forces.

The Heisenberg uncertainty principle suggests that protons can 'borrow' energy in order to overcome their electrostatic repulsion. This allows fusion to occur at lower temperatures than would otherwise be required.

Use your knowledge of physics to comment on this excerpt.

3



* X 7 5 7 7 7 0 1 2 0 *

MARKS

DO NOT
WRITE IN
THIS
MARGIN

9. (continued)



* X 7 5 7 7 7 0 1 2 1 *

10. (a) Alpha particles are accelerated to a speed of $5.0 \times 10^6 \text{ m s}^{-1}$.
 The alpha particles are then injected into a magnetic field. The path of the alpha particles is perpendicular to the magnetic field lines.
 The magnetic induction is 1.7 T .
 The alpha particles follow the circular path shown in Figure 10A.

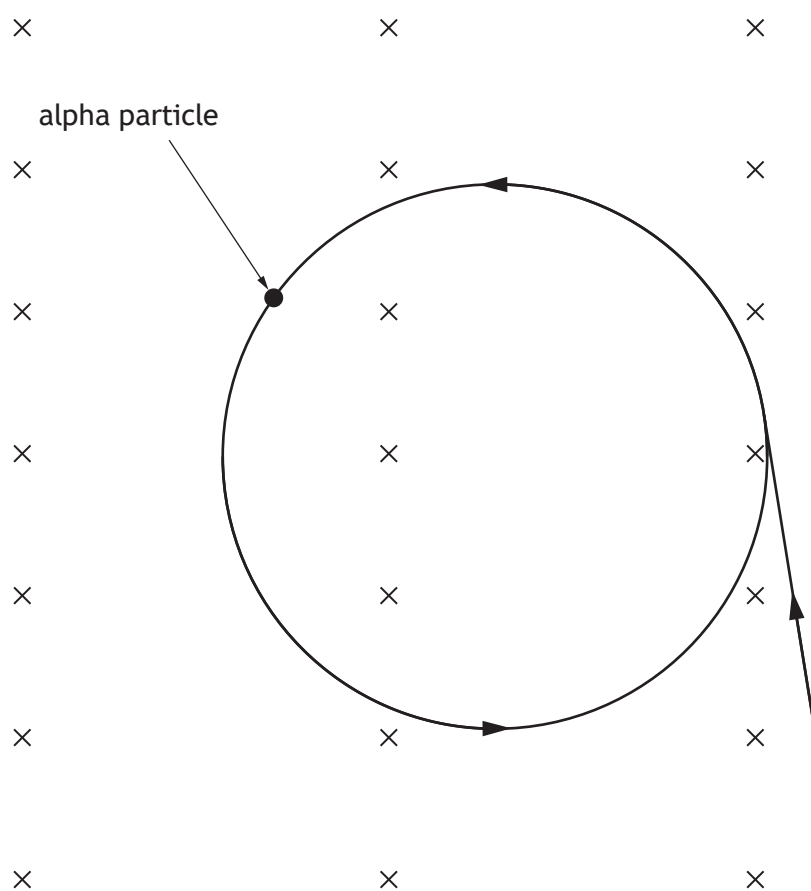

Figure 10A

- (i) (A) Calculate the magnitude of the magnetic force acting on an alpha particle.

3

Space for working and answer



10. (a) (i) (continued)

(B) This magnetic force provides the centripetal force that causes the alpha particles to follow the circular path.

Calculate the radius of the circular path.

3

Space for working and answer

(ii) The alpha particles are now replaced by protons.

The protons also travel at $5.0 \times 10^6 \text{ m s}^{-1}$, and are injected into the magnetic field at the same point and in the same direction as the alpha particles.

On Figure 10A, sketch the path followed by the protons after they enter the magnetic field.

3

(An additional diagram, if required, can be found on *page 46*)



* X 7 5 7 7 7 0 1 2 3 *

10. (continued)

(b) Cosmic rays travel through space towards Earth.

Approximately 9% of cosmic rays are alpha particles.

Alpha particles entering the magnetic field of the Earth follow a **helical**, rather than a **circular** path.

Explain why alpha particles travelling through the magnetic field of the Earth follow a helical path.

2



* X 7 5 7 7 7 0 1 2 4 *

10. (continued)

- (c) The Pierre Auger Observatory is a large cosmic ray observatory in Argentina. The location of this observatory is shown in Figure 10B.



Figure 10B

The observatory is at an altitude of 1400 m.

Explain why this choice of location for the observatory was preferred to locations at lower altitude **and** to locations closer to the equator.

2



11. A home improvement shop has a machine that can produce paint of any colour. Small amounts of pigment are added to paint in a tin. The tin is then shaken to produce a uniform colour of paint.

The machine is shown in Figure 11A.

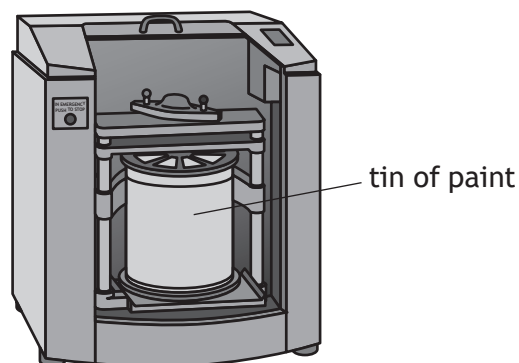

Figure 11A

The tin is placed in the machine and clamped securely. During shaking, the oscillation of the tin in the vertical plane can be modelled as simple harmonic motion.

The tin of paint has a mass of 3.67 kg.

The tin is shaken at a rate of 580 oscillations per minute.

The amplitude of its motion is 0.013 m.

- (a) (i) Show that the angular frequency ω of the tin is 61 rad s^{-1} . 2
Space for working and answer

- (ii) Calculate the maximum kinetic energy of the tin. 3
Space for working and answer



11. (a) (continued)

- (iii) On the axes below, sketch a graph showing the variation of the kinetic energy E_k of the tin with the vertical displacement y from its equilibrium position.

Numerical values are required on both axes.

3

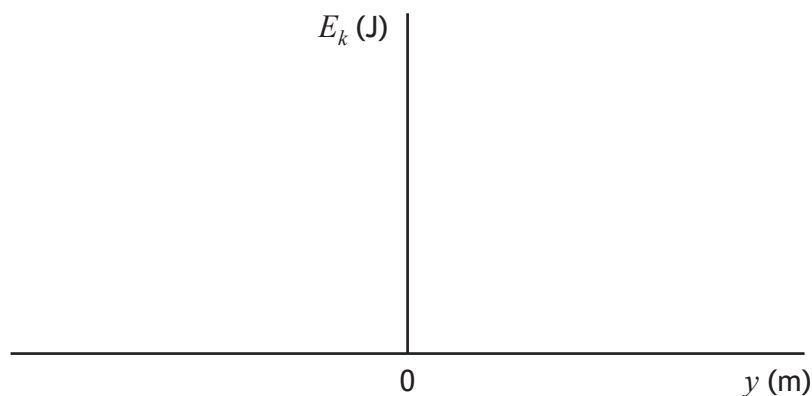

(An additional graph, if required, can be found on *page 47*.)

- (b) A coin falls onto the lid of the tin of paint as it is being clamped into position. The coin loses contact with the lid during the first oscillation.

- (i) State the magnitude and direction of the acceleration of the tin when the coin just loses contact with the lid.

1

- (ii) Determine the magnitude of the displacement of the tin from its equilibrium position when the coin just loses contact with the lid.

3

Space for working and answer



12. A student is performing an experiment to determine the speed of sound in air.

The student uses the apparatus shown in Figure 12A.

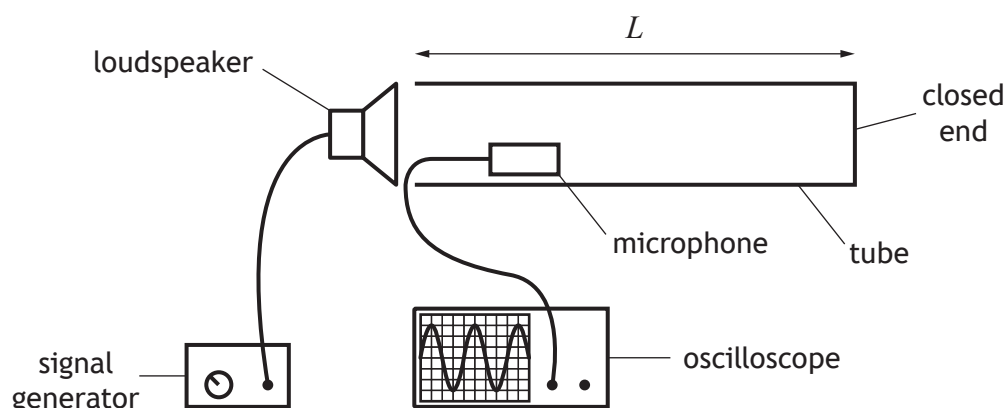

Figure 12A

The microphone is in a fixed position.

The signal generator is switched on.

A stationary wave is formed within the tube.

(a) (i) Explain how the stationary wave is formed.

1

(ii) At one frequency the microphone detects a loud sound. The frequency produced by the signal generator is now increased gradually.

Describe what happens to the loudness of the sound detected by the microphone as the frequency is being increased to twice its original value.

2



12. (continued)

(b) At specific frequencies the air in the tube will resonate.

Frequencies that cause resonance can be determined by the relationship

$$f = \frac{nv}{4L}$$

where

v is the speed of sound in air

L is the length of the tube

n is the number of half-wavelengths of sound waves in the tube.

The student measures the length of the tube to be (2.00 ± 0.02) m.

The student notes that the resonant frequency is (510 ± 10) Hz when there are eleven half-wavelengths of sound waves in the tube.

- (i) Use the data obtained by the student to calculate a value for the speed of sound in air. 2

Space for working and answer.

- (ii) Determine the absolute uncertainty in this value. 4

Space for working and answer.



* X 7 5 7 7 7 0 1 2 9 *

12. (continued)

- (c) The student now uses a graphical method to determine the speed of sound in air. Using a software graphing package, the student produces the graph shown in Figure 12B.

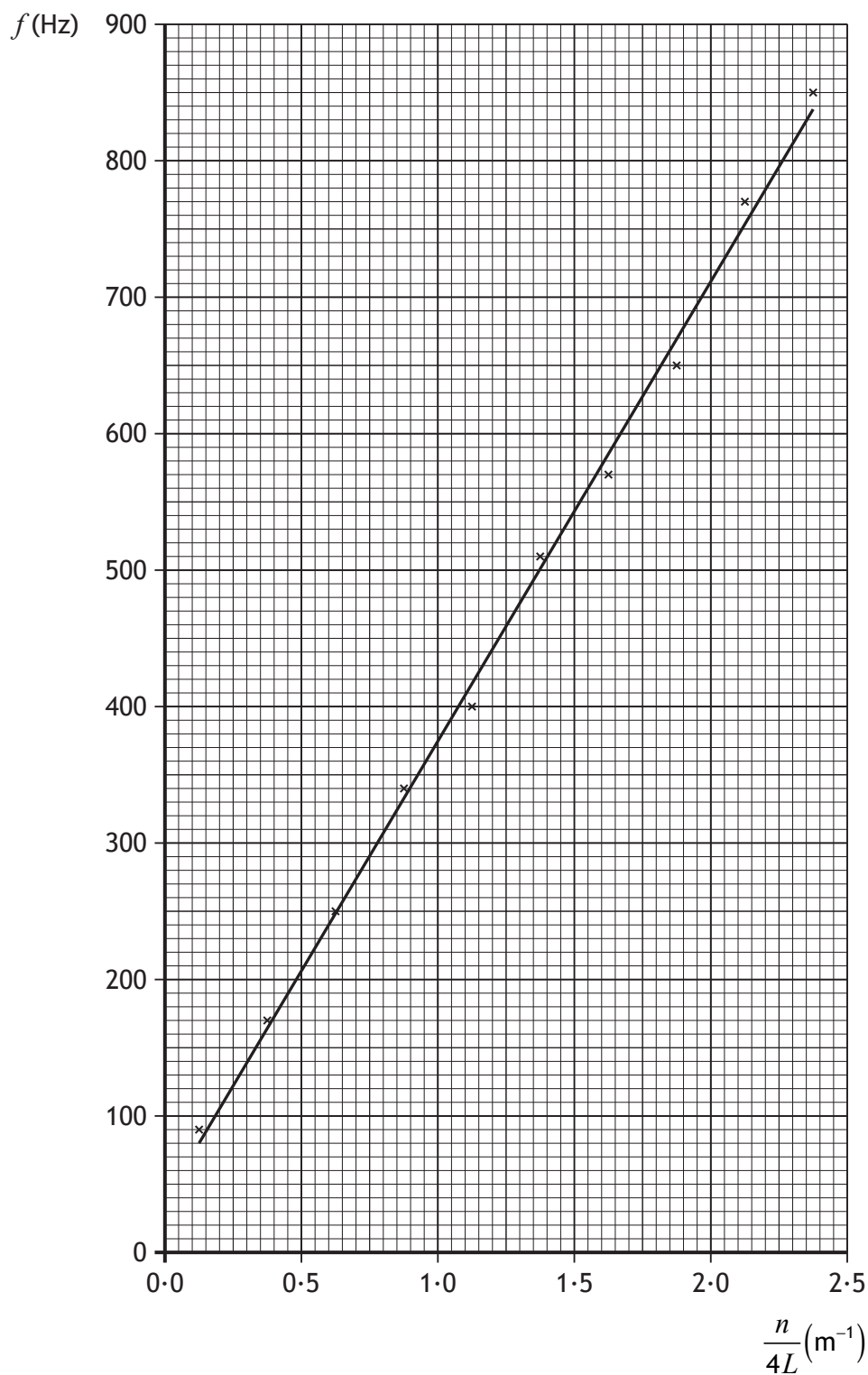

Figure 12B



12. (c) (continued)

- (i) Using information from the graph, determine the speed of sound in air.

3

Space for working and answer.

- (ii) Using the graphing package, the student estimates a 2% uncertainty in the value of the speed of sound in air obtained.

(A) State how the *precision* of the value obtained by the graphical method compares with the *precision* of the value obtained in (b).

1

(B) State how the *accuracy* of the value obtained by the graphical method compares with the *accuracy* of the value obtained in (b).

1

- (iii) The line of best fit on the graph does not pass through the origin as theory predicts. This may be due to a systematic uncertainty.

Suggest a possible source of a systematic uncertainty in the experiment.

1



* X 7 5 7 7 7 0 1 3 1 *

13. A student uses a double slit to produce an interference pattern with green light from an LED. This is shown in Figure 13A.

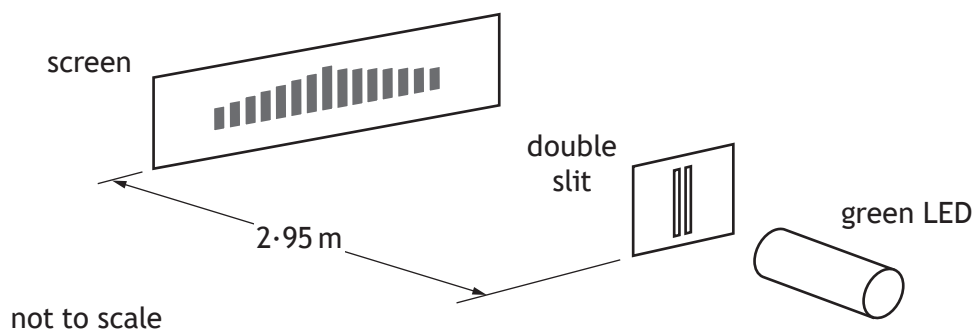

Figure 13A

The LED emits light of wavelength 550 nm.

The student makes the following measurements.

14 fringe separations	43.4 mm
Distance from slits to screen	2.95 m

- (a) (i) Determine the distance between the slits.

4

Space for working and answer

- (ii) Explain why the student measured 14 fringe separations rather than measuring the separation of two adjacent fringes.

1



13. (continued)

(b) The student replaces the green LED with an LED that emits red light.

Apart from colour, state how the fringe pattern now observed by the student differs from the pattern produced by the green LED.

You must justify your answer.

2

[Turn over



* X 7 5 7 7 7 0 1 3 3 *

13. (continued)

- (c) A second student uses a different arrangement to produce an interference pattern.

Monochromatic light of wavelength 550 nm is shone onto a soap film at nearly normal incidence. The light is reflected from the soap film and an interference pattern is visible on the film.

This arrangement is shown in Figure 13B.

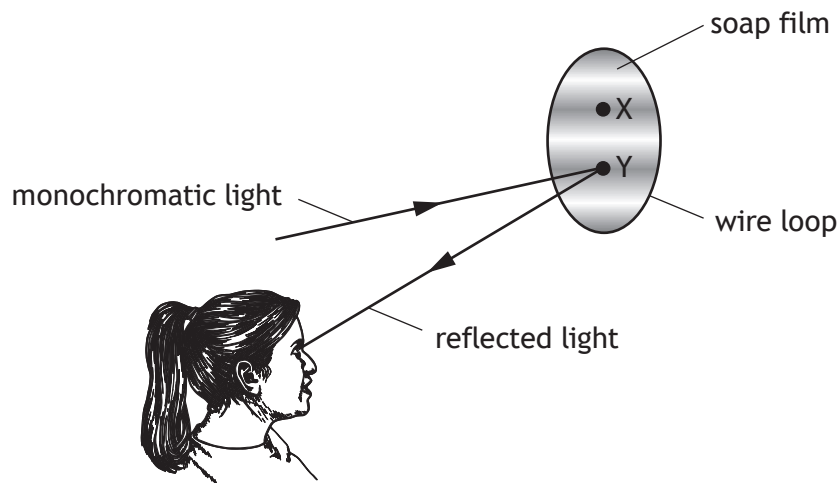

Figure 13B

An expanded side view of the soap film and light rays is shown in Figure 13C.

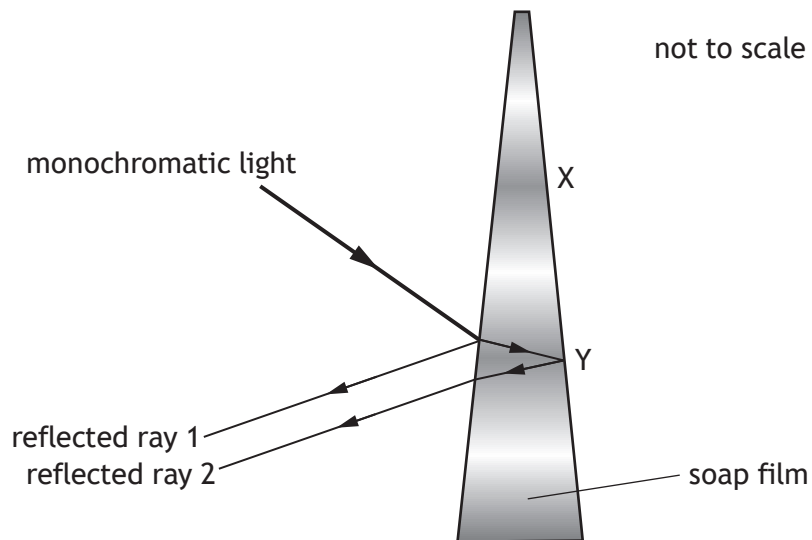

Figure 13C



13. (c) (continued)

- (i) At Y the thickness of the film is 3.39×10^{-6} m.

The refractive index of the film is 1.46.

Determine the optical path difference between reflected ray 1 and reflected ray 2.

3

Space for working and answer

- (ii) There is an area of destructive interference at Y.

The next area of destructive interference occurs at X, where the film is slightly thinner.

Determine the optical path difference between the reflected rays at X.

1

Space for working and answer



* X 7 5 7 7 7 0 1 3 5 *

14. (a) (i) A point charge of $+1.3 \times 10^{-14} \text{ C}$ is placed 48 mm from point P.
 Show that the electrical potential at P due to this charge is $2.4 \times 10^{-3} \text{ V}$.
 Space for working and answer.

2

- (ii) A second point charge, of $-1.3 \times 10^{-14} \text{ C}$, is now placed 52 mm from P.
 This is shown in Figure 14A.

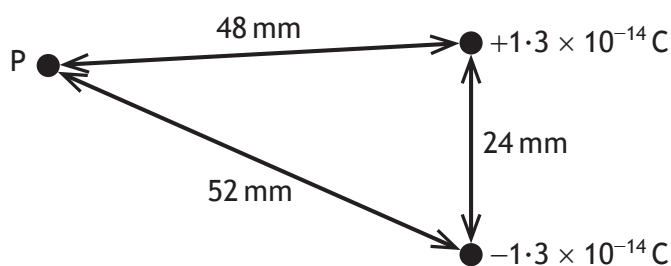

Figure 14A

- Determine the electrical potential at P due to both charges.
 Space for working and answer.

3



14. (continued)

- (b) Some virtual reality headsets detect changes in electrical potential caused by movement of charge within the human eye.

The human eye can be modelled as two point charges.

In this model there is a positive charge near the front of the eye (iris), and a negative charge near the back of the eye (retina).

This is shown in Figure 14B.

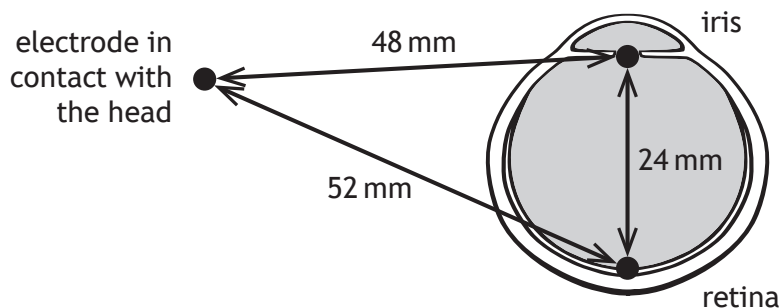

Figure 14B

When the eye looks from side to side, the positive charge moves while the negative charge remains in a fixed position.

An electrode in contact with the head can measure the electrical potential at that point due to these charges.

State what happens to the electrical potential at the electrode as the iris moves towards the electrode.

You must justify your answer.

2



[BLANK PAGE]

DO NOT WRITE ON THIS PAGE



* X 7 5 7 7 7 0 1 3 8 *

15. A small, thin, rectangular, metal plate is connected to a d.c. power supply as shown in Figure 15A.

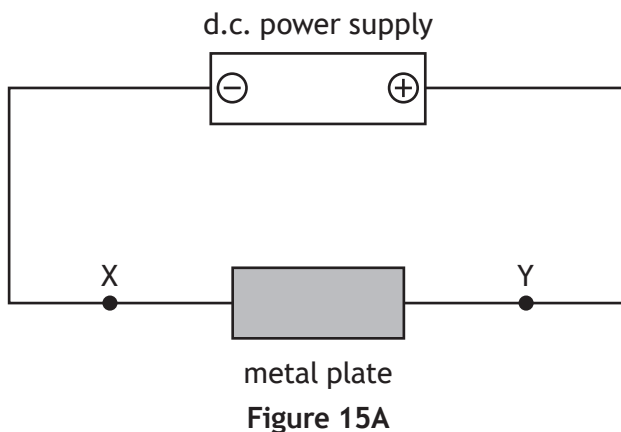

Electrons move through the plate from left to right.

A uniform magnetic field is now applied at right angles to the plate.

This is shown in Figure 15B.

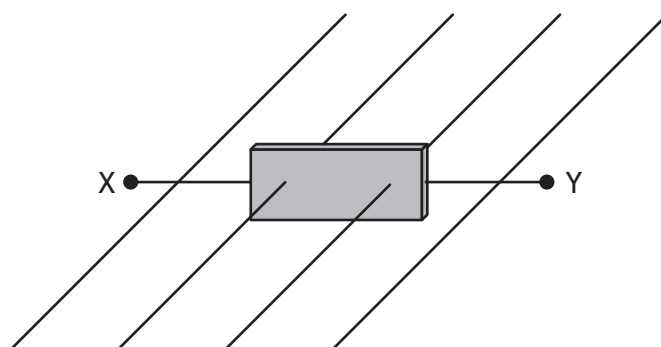

As the electrons enter the metal plate they experience a force due to the magnetic field. This causes the electrons to initially follow a curved path downwards and gather at the bottom of the metal plate.

- (a) Determine whether the direction of the magnetic field is into the page or out of the page.

1



15. (continued)

- (b) After a short time, the bottom of the plate becomes negatively charged relative to the top of the plate, as shown in Figure 15C.

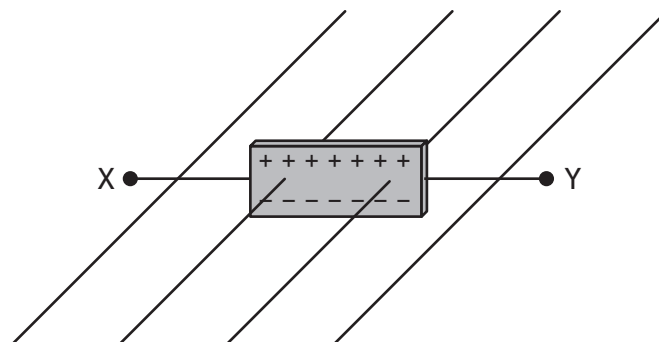

Figure 15C

This causes a uniform electric field between the top and bottom of the metal plate.

Electrons moving at a fixed speed v_d , called the *drift velocity*, will now travel horizontally across the plate. These electrons do not move vertically as the electric and magnetic forces acting on them are balanced.

- (i) Show that the drift velocity is given by the relationship

$$v_d = \frac{V}{Bd}$$

where

V is the potential difference between the top and bottom of the metal plate

B is the magnetic induction

d is the height of the metal plate.

3



15. (b) (continued)

(ii) The metal plate has a height of 3.25×10^{-2} m.
 The magnetic induction is 1.25 T.
 The potential difference between the top of the plate and the bottom of the plate is 3.47×10^{-6} V.
 Calculate the drift velocity of the electrons moving across the plate. **2**
Space for working and answer

(iii) The magnetic induction is now increased. The drift velocity of the electrons moving through the metal plate remains the same. **2**
 Explain why the drift velocity does not change.



16. A technician finds an unlabelled capacitor and carries out an experiment to determine its capacitance.

The technician builds a circuit using a battery, a $2.2\text{ k}\Omega$ resistor, a voltmeter and the unlabelled capacitor. The technician constructs the circuit so that the potential difference across the capacitor is measured as it charges.

(a) (i) Draw a diagram of a circuit that would enable the technician to carry out this experiment.

1

(ii) The data obtained from the experiment are used to draw the graph of potential difference V against time t shown in Figure 16A.

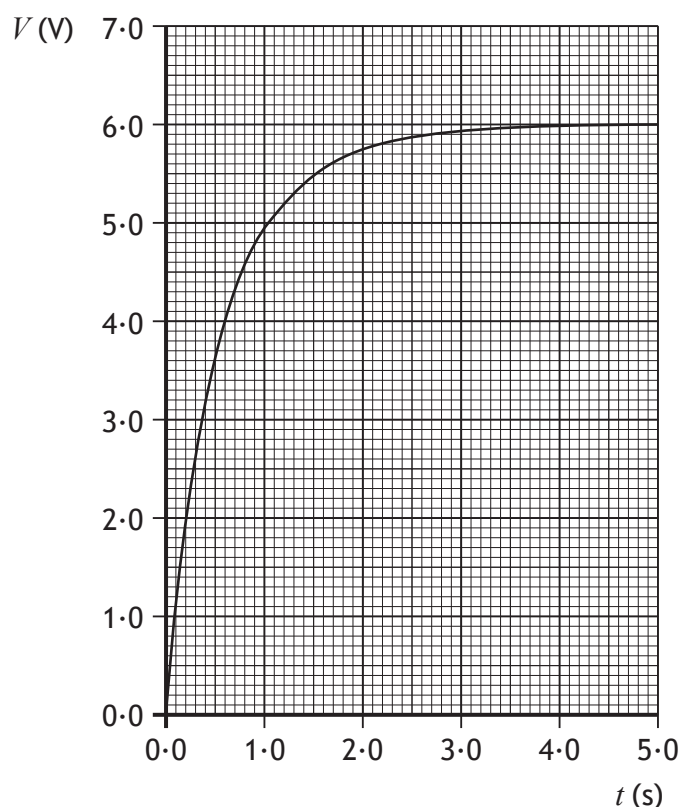

Figure 16A

Use the graph to determine the time constant of this circuit.

2

Space for working and answer



* X 7 5 7 7 7 0 1 4 2 *

16. (a) (continued)

(iii) Calculate the capacitance of the unlabelled capacitor.

Space for working and answer.

3

(b) The technician also finds an unlabelled inductor and wishes to determine its inductance.

(i) The technician connects the inductor to a data logger, a switch and a 9.0V d.c. supply. When the circuit is switched on, the initial rate of change of current is determined to be 95.8 A s^{-1} .

Calculate the inductance of the inductor.

Space for working and answer.

3

(ii) The technician connects the inductor and a d.c. ammeter to a 9.0V d.c. power supply. The technician records the maximum ammeter reading.

The technician then connects the inductor and an a.c. ammeter to a 9.0V r.m.s. a.c. power supply. The technician again records the maximum ammeter reading.

The technician notices that the values of current recorded are different.

State which ammeter displays the greater current reading.

You must justify your answer.

2

[END OF QUESTION PAPER]



* X 7 5 7 7 7 0 1 4 3 *

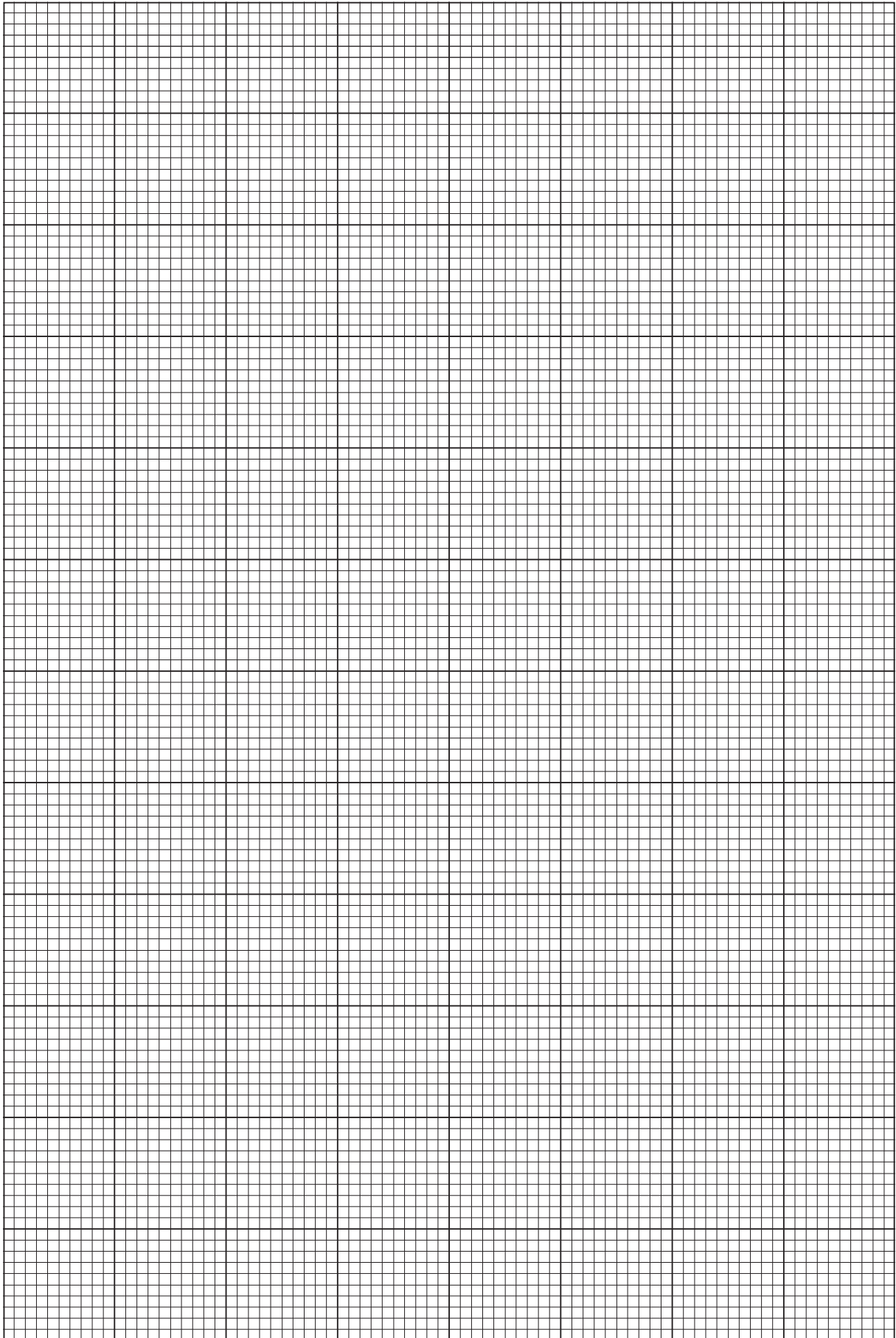

* X 7 5 7 7 7 0 1 4 4 *

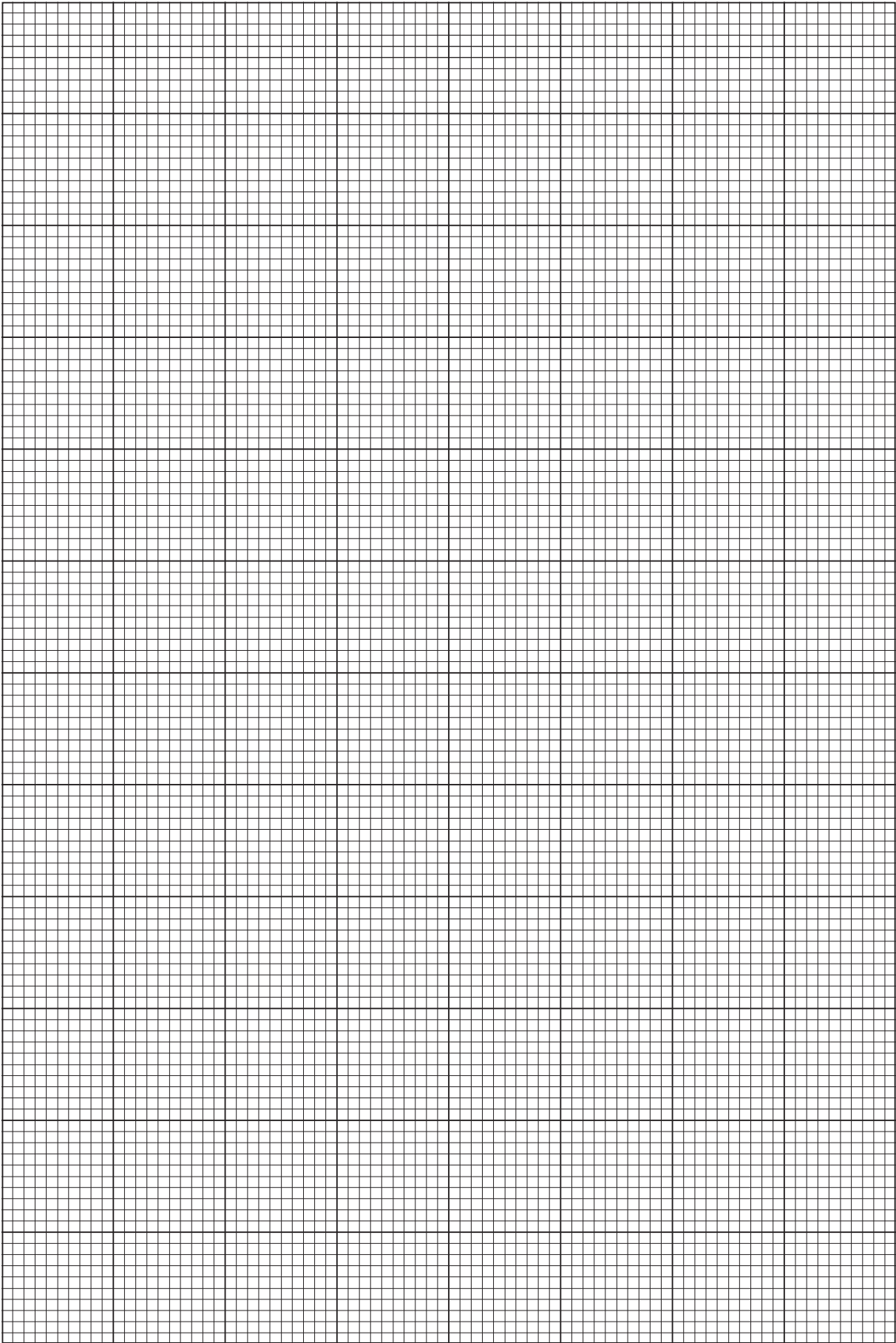

* X 7 5 7 7 7 0 1 4 5 *

ADDITIONAL SPACE FOR ANSWERS AND ROUGH WORK

Additional diagram for use with Question 6 (c) (ii) (B)

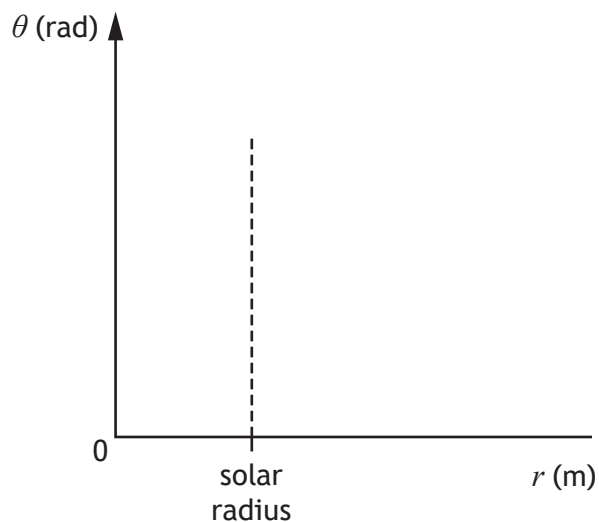

Additional diagram for use with Question 10 (a) (ii)

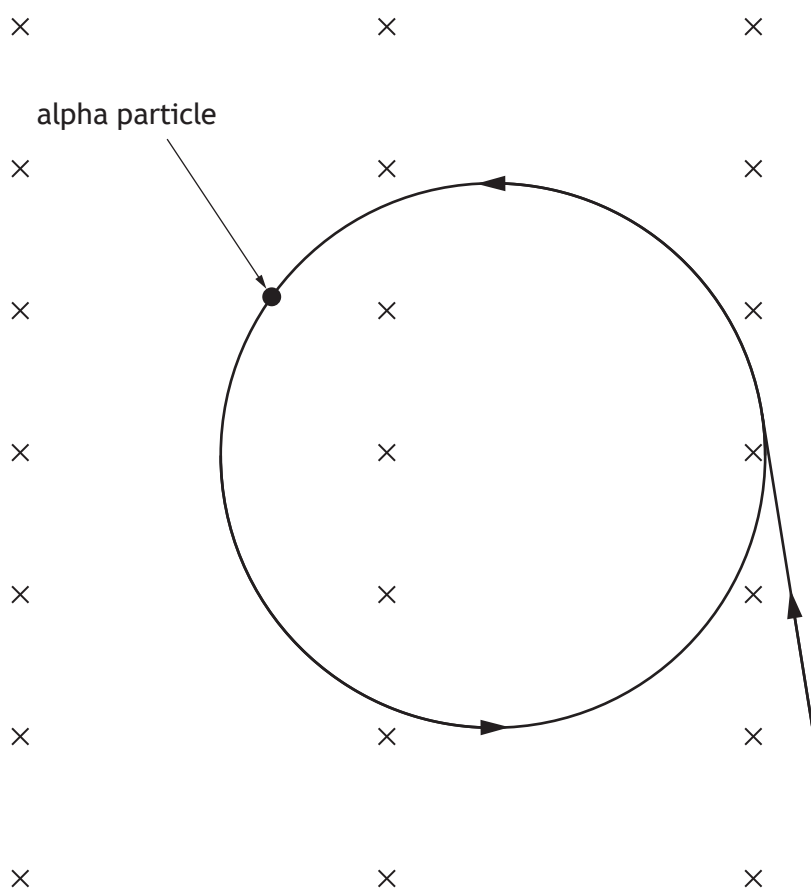

MARKS

DO NOT
WRITE IN
THIS
MARGIN

ADDITIONAL SPACE FOR ANSWERS AND ROUGH WORK

Additional graph for use with Question 11 (a) (iii)

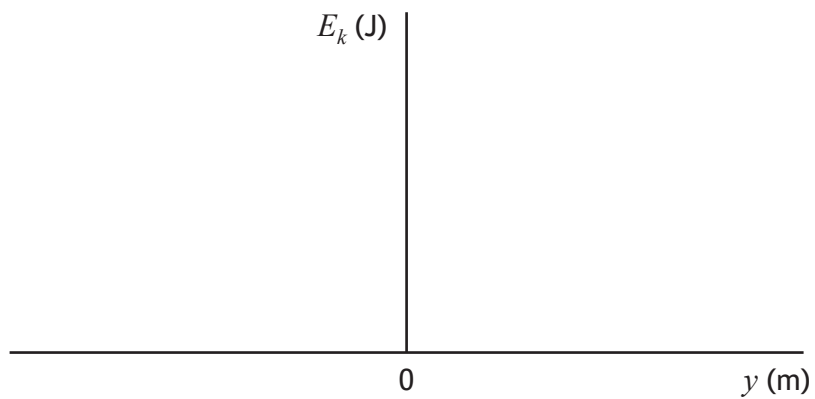

* X 7 5 7 7 7 0 1 4 7 *

MARKS

DO NOT
WRITE IN
THIS
MARGIN

ADDITIONAL SPACE FOR ANSWERS AND ROUGH WORK



* X 7 5 7 7 7 0 1 4 8 *

MARKS DO NOT
WRITE IN
THIS
MARGIN

ADDITIONAL SPACE FOR ANSWERS AND ROUGH WORK



* X 7 5 7 7 7 0 1 4 9 *

[BLANK PAGE]

DO NOT WRITE ON THIS PAGE



* X 7 5 7 7 7 0 1 5 0 *

[BLANK PAGE]

DO NOT WRITE ON THIS PAGE



* X 7 5 7 7 7 0 1 5 1 *

[BLANK PAGE]

DO NOT WRITE ON THIS PAGE

Acknowledgement of copyright

Question 2(a) Elena Rostunova/shutterstock.com
Question 3(a) Inspring/shutterstock.com
Question 4 Yuri Schmidt/shutterstock.com
Question 5 Golden Sikorka/shutterstock.com
Question 10 Pyty/shutterstock.com



* X 7 5 7 7 7 0 1 5 2 *