

FOR OFFICIAL USE



--	--	--	--	--	--

National
Qualifications
2023

Mark

--

X857/77/01

Physics

WEDNESDAY, 17 MAY
9:00 AM – 12:00 NOON



Fill in these boxes and read what is printed below.

Full name of centre

--

Town

--

Forename(s)

--

Surname

--

Number of seat

--

Date of birth

Day

Month

Year

--	--

--	--

--	--

Scottish candidate number

--	--	--	--	--	--	--	--	--	--

Total marks — 155

Attempt ALL questions.

Reference may be made to the Physics relationships sheet X857/77/11 and the data sheet on page 02.

Write your answers clearly in the spaces provided in this booklet. Additional space for answers and rough work is provided at the end of this booklet. If you use this space you must clearly identify the question number you are attempting. Any rough work must be written in this booklet. You should score through your rough work when you have written your final copy.

Care should be taken to give an appropriate number of significant figures in the final answers to calculations.

Use **blue** or **black** ink.

Before leaving the examination room you must give this booklet to the Invigilator; if you do not, you may lose all the marks for this paper.



DATA SHEET

COMMON PHYSICAL QUANTITIES

Quantity	Symbol	Value	Quantity	Symbol	Value
Gravitational acceleration on Earth	g	9.8 m s^{-2}	Mass of electron	m_e	$9.11 \times 10^{-31} \text{ kg}$
Radius of Earth	R_E	$6.4 \times 10^6 \text{ m}$	Charge on electron	e	$-1.60 \times 10^{-19} \text{ C}$
Mass of Earth	M_E	$6.0 \times 10^{24} \text{ kg}$	Mass of neutron	m_n	$1.675 \times 10^{-27} \text{ kg}$
Mass of Moon	M_M	$7.3 \times 10^{22} \text{ kg}$	Mass of proton	m_p	$1.673 \times 10^{-27} \text{ kg}$
Radius of Moon	R_M	$1.7 \times 10^6 \text{ m}$	Mass of positron	m_{e^+}	$9.11 \times 10^{-31} \text{ kg}$
Mean Radius of Moon Orbit		$3.84 \times 10^8 \text{ m}$	Charge on positron	e^+	$1.60 \times 10^{-19} \text{ C}$
Solar radius		$6.955 \times 10^8 \text{ m}$	Charge on copper nucleus		$4.64 \times 10^{-18} \text{ C}$
Mass of Sun		$2.0 \times 10^{30} \text{ kg}$	Planck's constant	h	$6.63 \times 10^{-34} \text{ J s}$
Mass of Mars	M_{Mars}	$6.42 \times 10^{23} \text{ kg}$	Permittivity of free space	ϵ_0	$8.85 \times 10^{-12} \text{ F m}^{-1}$
Radius of Mars	R_{Mars}	$3.39 \times 10^6 \text{ m}$	Permeability of free space	μ_0	$4\pi \times 10^{-7} \text{ H m}^{-1}$
1 AU		$1.5 \times 10^{11} \text{ m}$	Speed of light in vacuum	c	$3.00 \times 10^8 \text{ m s}^{-1}$
Stefan-Boltzmann constant	σ	$5.67 \times 10^{-8} \text{ W m}^{-2} \text{ K}^{-4}$	Speed of sound in air	v	$3.4 \times 10^2 \text{ m s}^{-1}$
Universal constant of gravitation	G	$6.67 \times 10^{-11} \text{ m}^3 \text{ kg}^{-1} \text{ s}^{-2}$			

REFRACTIVE INDICES

The refractive indices refer to sodium light of wavelength 589 nm and to substances at a temperature of 273 K.

Substance	Refractive index	Substance	Refractive index
Diamond	2.42	Glycerol	1.47
Glass	1.51	Water	1.33
Ice	1.31	Air	1.00
Perspex	1.49	Magnesium fluoride	1.38

SPECTRAL LINES

Element	Wavelength (nm)	Colour	Element	Wavelength (nm)	Colour
Hydrogen	656	Red	Cadmium	644	Red
	486	Blue-green		509	Green
	434	Blue-violet		480	Blue
	410	Violet	Lasers		
	397	Ultraviolet	Element	Wavelength (nm)	Colour
	389	Ultraviolet	Carbon dioxide	9550 } 10590 }	Infrared
Sodium	589	Yellow	Helium-neon	633	Red

PROPERTIES OF SELECTED MATERIALS

Substance	Density (kg m^{-3})	Melting Point (K)	Boiling Point (K)	Specific Heat Capacity ($\text{J kg}^{-1} \text{ K}^{-1}$)	Specific Latent Heat of Fusion (J kg^{-1})	Specific Latent Heat of Vaporisation (J kg^{-1})
Aluminium	2.70×10^3	933	2623	9.02×10^2	3.95×10^5
Copper	8.96×10^3	1357	2853	3.86×10^2	2.05×10^5
Glass	2.60×10^3	1400	6.70×10^2
Ice	9.20×10^2	273	2.10×10^3	3.34×10^5
Glycerol	1.26×10^3	291	563	2.43×10^3	1.81×10^5	8.30×10^5
Methanol	7.91×10^2	175	338	2.52×10^3	9.9×10^4	1.12×10^6
Sea Water	1.02×10^3	264	377	3.93×10^3
Water	1.00×10^3	273	373	4.18×10^3	3.34×10^5	2.26×10^6
Air	1.29
Hydrogen	9.0×10^{-2}	14	20	1.43×10^4	4.50×10^5
Nitrogen	1.25	63	77	1.04×10^3	2.00×10^5
Oxygen	1.43	55	90	9.18×10^2	2.40×10^4

The gas densities refer to a temperature of 273 K and a pressure of $1.01 \times 10^5 \text{ Pa}$.



* X 8 5 7 7 7 0 1 0 2 *

[Turn over for next question

DO NOT WRITE ON THIS PAGE



* X 8 5 7 7 7 0 1 0 3 *

Total marks — 155
Attempt ALL questions

1. A hot air balloon accelerates vertically upwards from the ground.

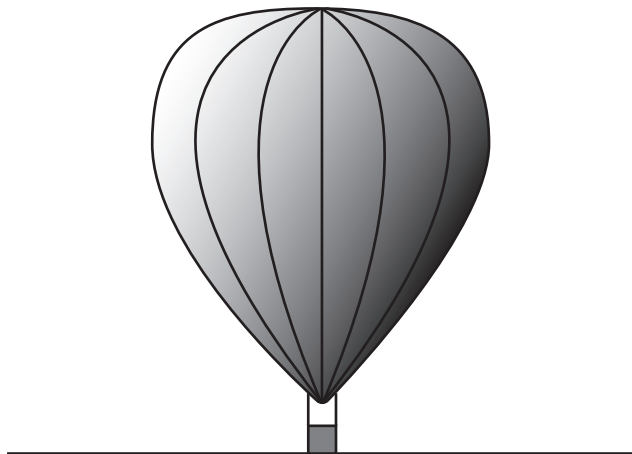

During the first 8.0 seconds of flight, the vertical velocity v of the balloon is given by the relationship

$$v = 0.0044t^3 + 0.012t^2$$

where v is measured in m s^{-1} and t is measured in s.

Using calculus methods:

- (a) determine the vertical acceleration of the balloon at $t = 8.0$ s

3

Space for working and answer



* X 8 5 7 7 7 0 1 0 4 *

1. (continued)

(b) determine the vertical displacement of the balloon at $t = 8.0$ s.

3

Space for working and answer

[Turn over



* X 8 5 7 7 7 0 1 0 5 *

2. A student is investigating rotational motion using the circular plate in a microwave oven. This is shown in Figure 2A.



Figure 2A

- (a) The microwave oven is switched on and the plate rotates with an angular velocity of 6.2 revolutions per minute.

Show that the angular velocity of the plate is 0.65 rad s^{-1} .

2

Space for working and answer



2. (continued)

- (b) The microwave oven is switched off. The student places a pea on the plate, 83 mm from the axis of rotation as shown in **Figure 2B**.

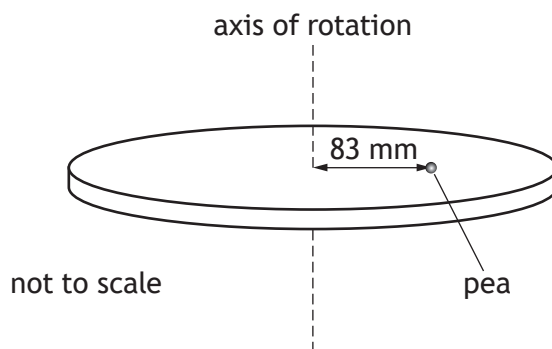

Figure 2B

The microwave oven is now switched on and the plate again rotates with an angular velocity of 0.65 rad s^{-1} .

- (i) The pea has a mass of 0.36 g and follows a circular path.

Calculate the centripetal force acting on the pea.

3

Space for working and answer

- (ii) State the direction of the centripetal force.

1

[Turn over



2. (continued)

- (c) The microwave oven is again switched off. The student places a second, identical pea on the plate, 120 mm from the axis of rotation as shown in Figure 2C.

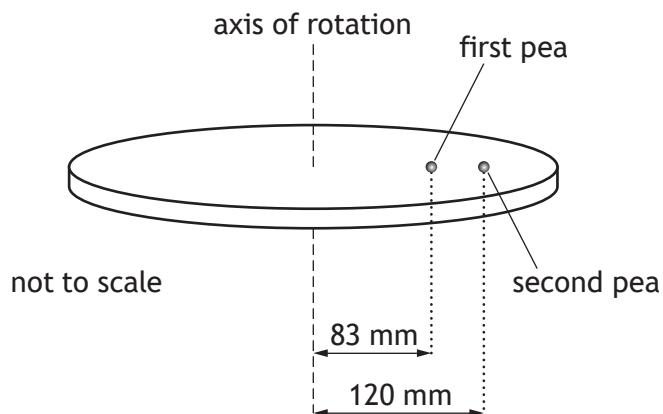

Figure 2C

The microwave oven is switched on.

Explain why the second pea is less likely to follow a circular path as the plate reaches an angular velocity of 0.65 rad s^{-1} .

2



3. A rotational dynamics investigation is carried out using a turntable of radius 150 mm as shown in Figure 3A.

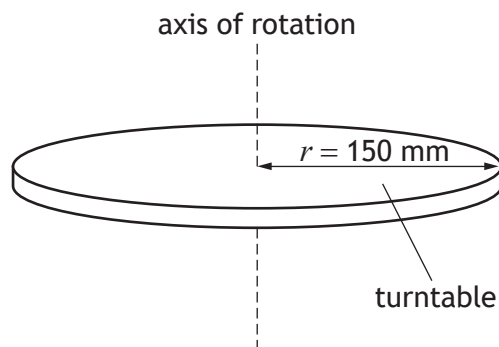

Figure 3A

- (a) The turntable consists of a uniform, solid disc of mass 0.82 kg.
 Show that the moment of inertia of this disc is $9.2 \times 10^{-3} \text{ kg m}^2$.
Space for working and answer

2

[Turn over



3. (continued)

(b) The turntable rotates at an angular velocity of 12 rad s^{-1} .

A thin ring is dropped gently onto the disc. The mass of the ring is 75 g.

The radius of the ring is 130 mm.

This system is shown in **Figure 3B**.

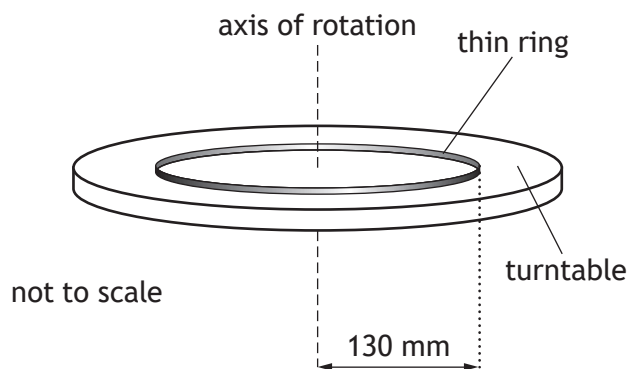

Figure 3B

(i) By considering the principle of conservation of angular momentum, determine the angular velocity of the system.

4

Space for working and answer



3. (b) (continued)

- (ii) Determine the loss in rotational kinetic energy due to the interaction between the ring and the turntable.

4

Space for working and answer

- (iii) During the interaction some rotational kinetic energy is converted into heat.

1

Explain how this heat is generated.

[Turn over



* X 8 5 7 7 7 0 1 1 1 *

4. In planning for a crewed mission to Mars, scientists have designed an Earth Return Vehicle (ERV). When the crew is on the surface of Mars, the ERV will be in a circular orbit around Mars at an altitude of 2.5×10^5 m above the surface.



- (a) Show that the gravitational potential at this altitude is -1.18×10^7 J kg⁻¹.

2

Space for working and answer



* X 8 5 7 7 7 0 1 1 2 *

4. (continued)

- (b) The ERV will then move into a higher circular orbit. The gravitational potential at the higher orbit is $-1.10 \times 10^7 \text{ J kg}^{-1}$.

The ERV will have a mass of $4.3 \times 10^3 \text{ kg}$.

Determine the change in gravitational potential energy of the ERV when it has moved from the lower orbit to the higher orbit.

4

Space for working and answer

[Turn over



* X 8 5 7 7 7 0 1 1 3 *

4. (continued)

(c) Another spacecraft, the Mars Ascent Vehicle (MAV), will transport crew and cargo from the surface of Mars to the ERV.

(i) Calculate the escape velocity from the surface of Mars.

3

Space for working and answer

(ii) The MAV will dock with the ERV in the higher circular orbit, at an altitude of 5.0×10^5 m above the surface of Mars.

Explain why the MAV does not have to attain the escape velocity calculated in (c) (i) to reach this altitude.

1



* X 8 5 7 7 7 0 1 1 4 *

4. (c) (continued)

(iii) Calculate the tangential speed of the ERV in this orbit.

3

Space for working and answer

(iv) Suggest a reason why the docking manoeuvre will be easier to carry out at an altitude of 5.0×10^5 m rather than at an altitude of 2.5×10^5 m.

1

[Turn over



* X 8 5 7 7 7 0 1 1 5 *

5. When discussing general relativity, the American physicist John Wheeler stated 'spacetime tells matter how to move; matter tells spacetime how to curve'.

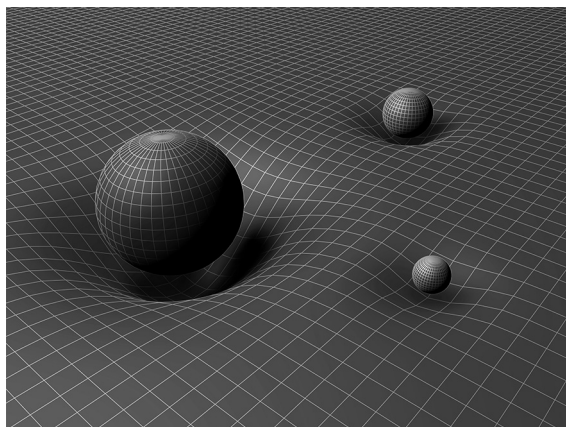

Using your knowledge of physics, comment on this statement.

3



5. (continued)

[Turn over



* X 8 5 7 7 7 0 1 1 7 *

6. The Sun is a main sequence star.

(a) In the core of the Sun, energy is released when hydrogen is converted to helium in a series of nuclear fusion reactions.

State the name given to this series of fusion reactions.

1

(b) The Sun has a surface temperature of 5800 K.

(i) Calculate the luminosity of the Sun.

Space for working and answer

3

(ii) State one assumption made in this calculation of luminosity.

1



* X 8 5 7 7 7 0 1 1 8 *

6. (continued)

- (c) When hydrogen fusion in its core stops, the Sun will leave the main sequence and become a red giant.

Explain, in terms of thermal pressure and gravitational forces, what happens to the radius of the Sun as it becomes a red giant.

2

[Turn over



* X 8 5 7 7 7 0 1 1 9 *

6. (continued)

- (d) The Plough is a pattern of seven bright stars in the constellation Ursa Major as shown in **Figure 6A**. Delta Ursae Majoris is the dimmest of these stars as viewed from Earth.

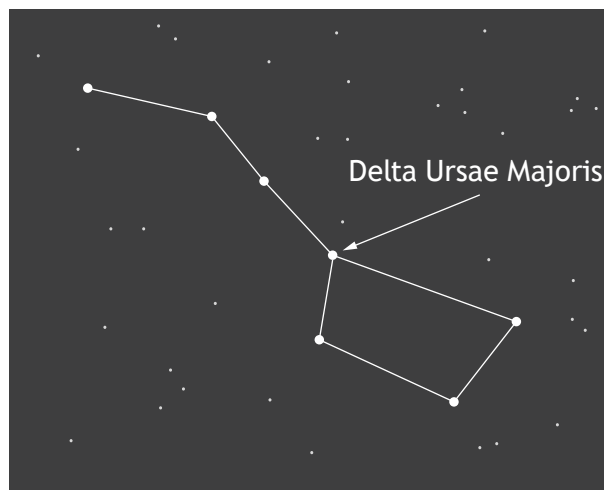

Figure 6A

The distance to Delta Ursae Majoris from Earth is 24.7 parsecs. 1 parsec is equal to 3.26 ly.

Delta Ursae Majoris has a luminosity of 5.46×10^{27} W.

Determine the apparent brightness of Delta Ursae Majoris when observed from Earth.

4

Space for working and answer



6. (continued)

MARKS DO NOT WRITE IN THIS MARGIN

(e) Epsilon Ursae Majoris is another of the stars in the Plough as shown in Figure 6B.

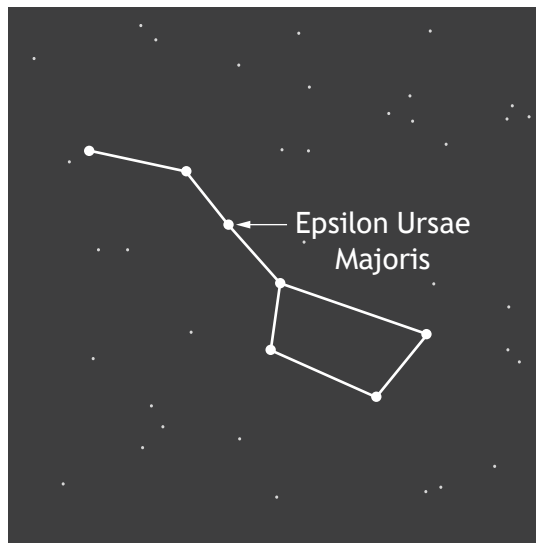

Figure 6B

The luminosity of Epsilon Ursae Majoris is approximately two orders of magnitude greater than the luminosity of the Sun. Epsilon Ursae Majoris has a surface temperature of approximately 9000 K.

On the HR diagram shown in Figure 6C, circle the star at the position of Epsilon Ursae Majoris.

(An additional diagram, if required, can be found on page 54.)

1

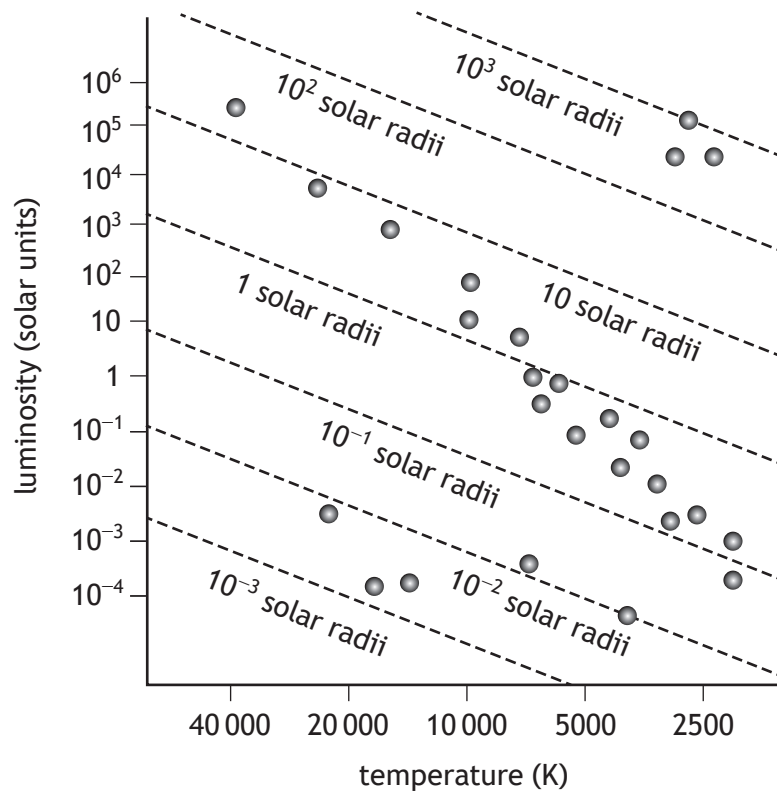

Figure 6C



7. The emission spectrum from a mercury vapour lamp includes a spectral line corresponding to photons of frequency 1.18×10^{15} Hz.

In practice, the spectral line is produced by photons with a range of frequencies Δf . This results in a spectral line of width $\Delta\lambda$, as shown in **Figure 7A**.

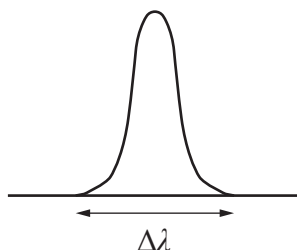

Figure 7A

The width of this spectral line can be explained using the Heisenberg uncertainty principle.

- (a) (i) State what is meant by the *Heisenberg uncertainty principle*. 1

- (ii) The range of photon frequencies is due to the uncertainty in photon energy ΔE .

The uncertainty in the photon energy can be determined from the lifetime of the electron Δt in the excited state.

The lifetime of an electron in this excited state is 1.2×10^{-13} s.

Determine the minimum uncertainty in the photon energy. 3

Space for working and answer



7. (a) (continued)

(iii) Determine the minimum uncertainty in the frequency of the emitted photon.

3

Space for working and answer

(b) The width of the spectral line can be calculated using the relationship

$$\Delta\lambda = \frac{c\Delta f}{f^2}$$

where $\Delta\lambda$ is the width of the spectral line in metres

Δf is the minimum uncertainty in the frequency of the emitted photon and the other symbols have their usual meaning.

Calculate the width of the spectral line.

2

Space for working and answer



* X 8 5 7 7 7 0 1 2 3 *

8. The Bohr model of the hydrogen atom states that the electron orbits the nucleus in discrete levels.

These levels correspond to quantised units of angular momentum.

- (a) The radius of the orbit of the electron around the nucleus of the hydrogen atom is given by the relationship

$$r = \frac{n^2 h^2 \epsilon_0}{\pi m_e e^2}$$

where the symbols have their usual meaning.

- (i) Calculate the radius of the orbit of the electron when it is in the ground state ($n = 1$).

2

Space for working and answer

- (ii) Determine the de Broglie wavelength of the electron in this orbit.

3

Space for working and answer



* X 8 5 7 7 7 0 1 2 4 *

8. (continued)

- (b) (i) By considering the centripetal force acting on the orbiting electron, show that the tangential speed v of the electron orbiting the nucleus at radius r is given by

$$v = \sqrt{\frac{Q_1 Q_2}{4\pi\epsilon_0 r m}}$$

where the symbols have their usual meaning.

Space for working and answer

2

- (ii) The electron now moves from the ground state to the orbit corresponding to $n = 2$.

State whether the tangential speed of the electron in this orbit is greater than, equal to or less than the tangential speed of the electron when it was in the ground state.

Justify your answer.

2

[Turn over



9. A bubble chamber is used to detect sub-atomic particles.

The chamber is filled with a liquid. There is a uniform magnetic field within the chamber, as shown in **Figure 9A**.

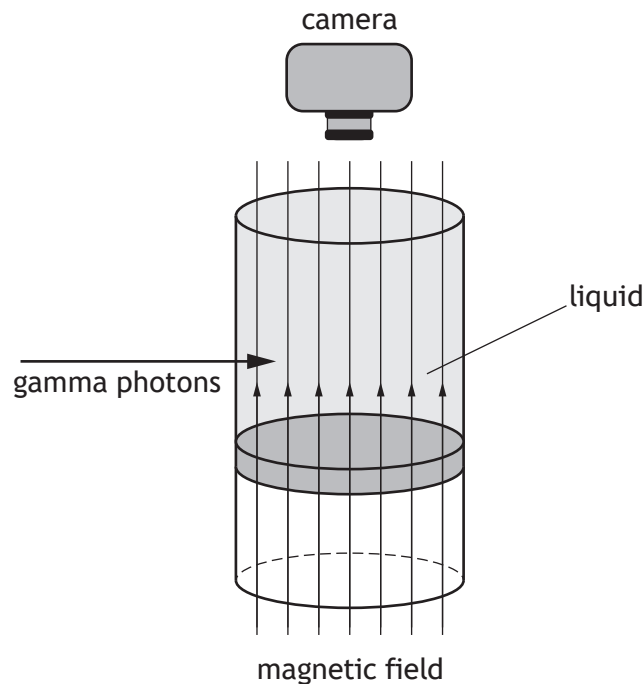

Figure 9A

A gamma photon enters the chamber and collides with an electron in an atom of the liquid. This electron is ejected from the atom. An electron-positron pair is also produced.

Figure 9B shows the incident gamma photon and the path of the particles following the collision.

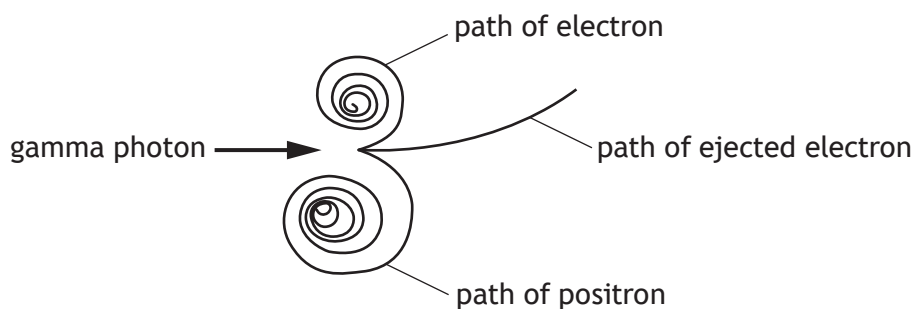

Figure 9B

The magnetic induction B in the bubble chamber is 2.20×10^{-2} T.

The initial radius of the path of the positron is 1.50×10^{-3} m.



* X 8 5 7 7 7 0 1 2 6 *

9. (continued)

- (a) (i) The initial radius of the path of the positron is determined using the relationship

$$r = \frac{mv}{qB}$$

Calculate the initial speed of the positron.

2

Space for working and answer

- (ii) Explain why the radius of the path of the positron decreases.

1

- (iii) Explain the two differences between the path followed by the ejected electron and the path followed by the positron.

2



* X 8 5 7 7 7 0 1 2 7 *

9. (continued)

- (b) Some of the energy of the gamma photon is required to produce the electron-positron pair. The remaining energy is converted to kinetic energy of the three particles.

The table shows these energies.

Energy required for production of electron-positron pair	1.02 MeV
Initial kinetic energy of produced positron	95.6 eV
Initial kinetic energy of produced electron	34.4 eV
Initial kinetic energy of ejected electron	1.70 MeV

Determine the frequency of the incident gamma photon.

4

Space for working and answer



[Turn over for next question

DO NOT WRITE ON THIS PAGE



* X 8 5 7 7 7 0 1 2 9 *

10. A loudspeaker consists of a coil of wire, attached to a cone, which is free to move in the field produced by a permanent magnet.

A simplified diagram of the loudspeaker is shown in **Figure 10A**.

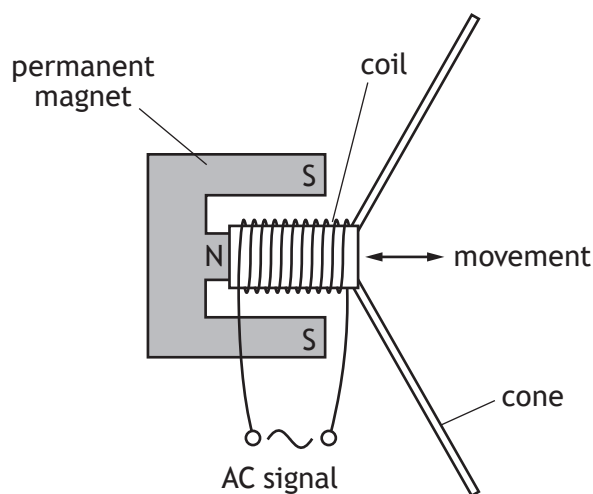

Figure 10A

The coil and cone oscillate when an AC signal is supplied to the coil.

The oscillation of the coil and cone can be modelled as simple harmonic motion.

- (a) State what is meant by *simple harmonic motion*.

1

- (b) An AC signal supplied to the coil has a frequency of 55.1 Hz.

- (i) Show that the angular frequency of the coil and cone is 346 rad s^{-1} .

2

Space for working and answer



* X 8 5 7 7 7 0 1 3 0 *

10. (b) (continued)

- (ii) The amplitude of the oscillation of the coil and cone is 8.24 mm.
Calculate the maximum acceleration of the coil and cone.

3

Space for working and answer

- (c) A magnetic force acts on the coil when there is current in the coil.
The following information is taken from the loudspeaker data sheet.

mass of coil and cone m	0.177 kg
magnetic induction B	1.10 T
length of conductor in coil l	21.8 m

By considering the magnetic force acting on the coil, determine the minimum current required to produce the maximum acceleration of the coil and cone.

4

Space for working and answer



* X 8 5 7 7 7 0 1 3 1 *

10. (continued)

- (d) The loudspeaker produces a sound wave.

The sound wave is described by the relationship

$$y = 8.24 \times 10^{-3} \sin 2\pi \left(55.1t - \frac{x}{6.00} \right)$$

Calculate the speed of the sound wave.

Space for working and answer

3

- (e) The amplitude of the sound wave is now reduced, and the energy of the wave decreases to 25% of its original value.

Determine the new amplitude of the sound wave.

Space for working and answer

3



* X 8 5 7 7 7 0 1 3 2 *

10. (continued)

(f) Critical damping is used in the operation of the loudspeaker.

The AC signal is turned off when the cone is at its maximum amplitude.

The coil and cone undergo critical damping and return to the equilibrium position.

On **Figure 10B**, sketch a graph showing how the displacement of the coil and cone varies with time during critical damping.

Numerical values are not required on either axis.

(An additional graph, if required, can be found on page 54.)

1

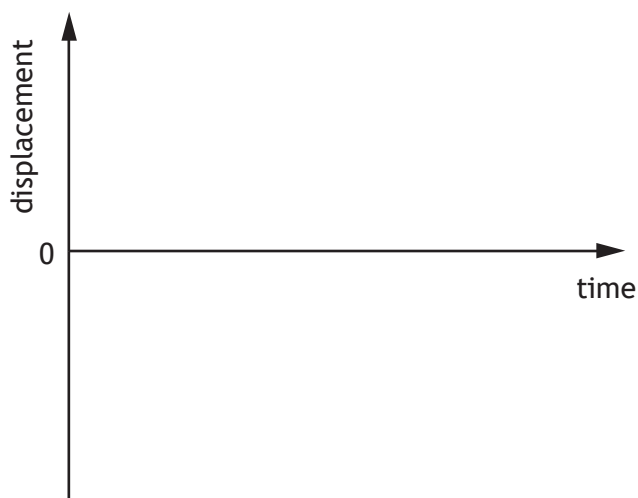

Figure 10B

[Turn over



11. A special type of lamp produces a cold, visible light beam.

The lamp consists of a light source and a glass reflector. The light source produces both visible and infrared radiation. The reflector reflects visible light.

The infrared radiation is emitted from the back of the reflector.

A cross section of the lamp is shown in **Figure 11A**.

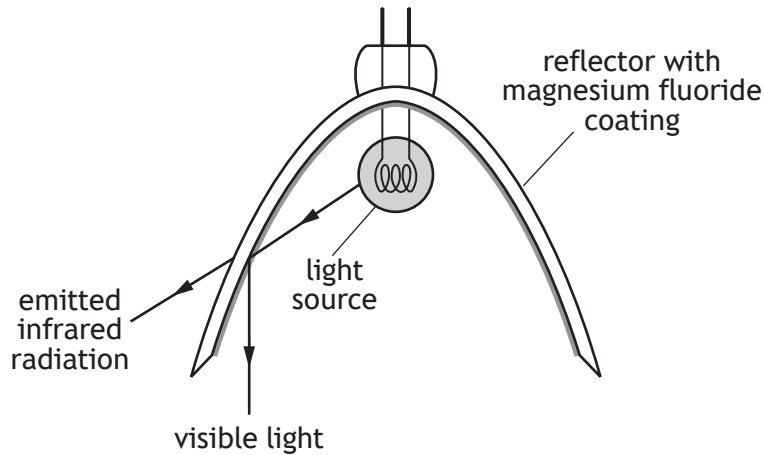

Figure 11A

The inside of the reflector is coated with a thin film of magnesium fluoride, which is non-reflecting for infrared radiation.

The refractive index of magnesium fluoride is 1.38 for infrared radiation.

The refractive index of glass is 1.50 for infrared radiation.

A diagram of a section of the reflector is shown in **Figure 11B**.

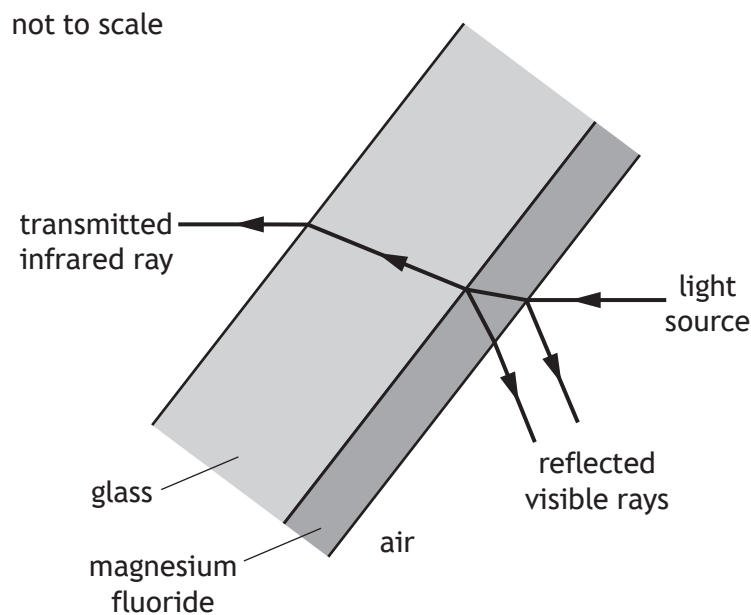

Figure 11B



* X 8 5 7 7 7 0 1 3 4 *

11. (continued)

(a) State the phase change, in radians, experienced by the visible light reflected from:

(i) the air-magnesium fluoride boundary

1

(ii) the magnesium fluoride-glass boundary.

1

(b) The peak wavelength of infrared radiation emitted from the light source is 967 nm.

Calculate the minimum thickness of magnesium fluoride required to ensure maximum transmission of infrared radiation of this wavelength into the glass.

3

Space for working and answer

[Turn over



* X 8 5 7 7 7 0 1 3 5 *

11. (continued)

- (c) Protective glass is placed in front of the lamp. This glass also has a thin film coating of magnesium fluoride, as shown in Figure 11C.

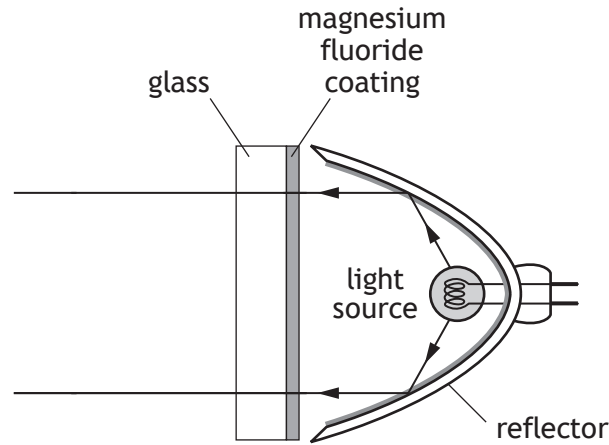

Figure 11C

The thin film allows maximum transmission of light of wavelength 550 nm through the protective glass.

The percentage of light transmitted through the protective glass for wavelengths across the range 400 nm – 850 nm is shown in Figure 11D.

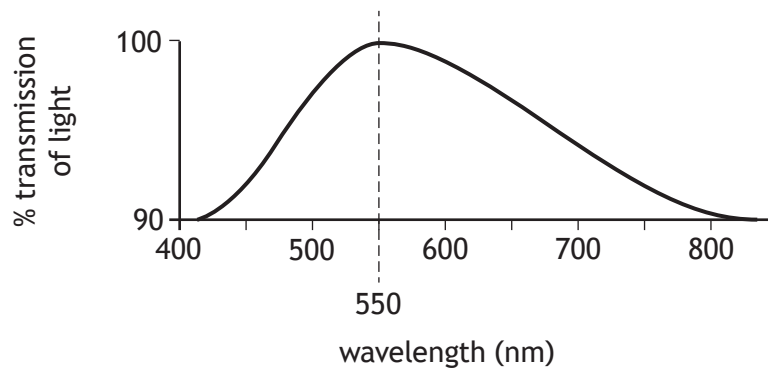

Figure 11D



11. (c) (continued)

- (i) On **Figure 11E**, draw a line showing the percentage of light **reflected** from the protective glass across this range of wavelengths.

1

(An additional diagram, if required, can be found on page 55.)

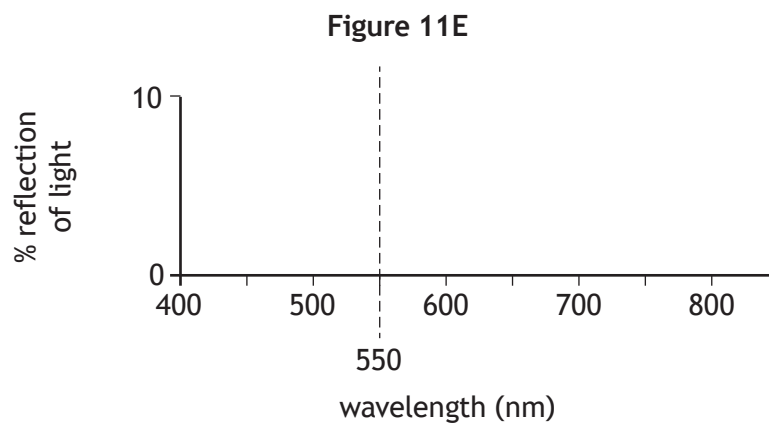

- (ii) Explain why the protective glass has a purple tint when reflected light from the surface of the glass is viewed.

1

[Turn over



12. (a) State what is meant by *plane-polarised light*.

1

(b) Unpolarised monochromatic light is incident on a glass block of refractive index n , at an angle i_p . This is shown in **Figure 12A**.

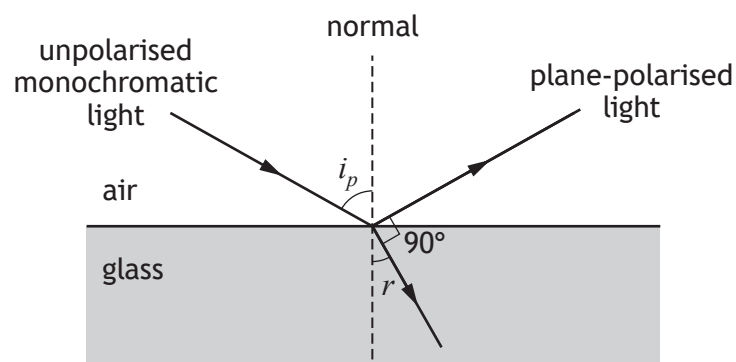

Figure 12A

Some of the light is refracted into the glass and the remaining light is reflected. The reflected light is plane-polarised.

Derive the relationship

$$n = \tan i_p$$

where i_p is Brewster's angle.

Space for working and answer

3



* X 8 5 7 7 7 0 1 3 8 *

12. (continued)

MARKS
DO NOT
WRITE IN
THIS
MARGIN

- (c) Sunlight can be plane-polarised when it is reflected from water.

A tram driver wears polarising sunglasses to reduce the glare from reflected sunlight. After a rain shower, sunlight is reflected from the surface of a puddle of water towards the tram. This is shown in **Figure 12B**.

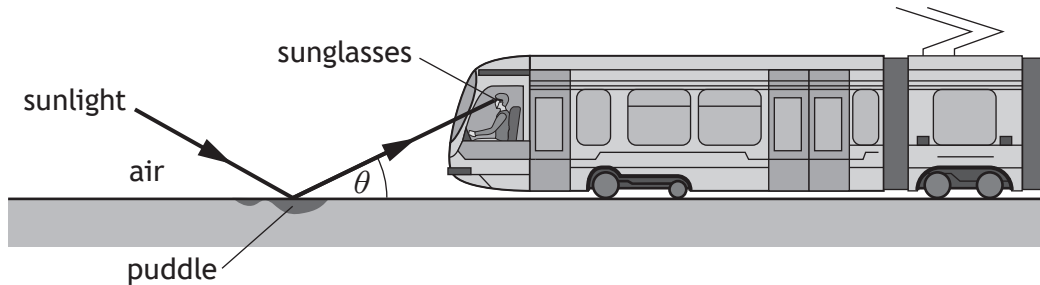

Figure 12B

not to scale

- (i) Determine the angle θ at which the sunlight reflected from the water surface is plane-polarised.

3

Space for working and answer

- (ii) By considering the transmission axis of the driver's sunglasses, explain why the sunglasses reduce glare from the puddle of water.

1

- (d) The tram driver observes a rainbow in the sky while still wearing polarising sunglasses. The driver notices that both ends of the rainbow are bright, but the brightness gradually decreases towards the highest point of the rainbow. Explain why the brightness of the rainbow varies as described.

2



13. A polar molecule is positively charged at one side and negatively charged at the other side.

One polar molecule can be modelled as two point charges connected together and separated by a fixed distance of 1.33×10^{-10} m. This is shown in **Figure 13A**.

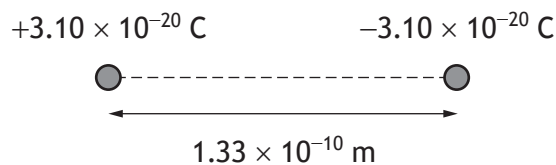

Figure 13A

- (a) Point P is 2.10×10^{-10} m to the right of the negative charge as shown in **Figure 13B**.

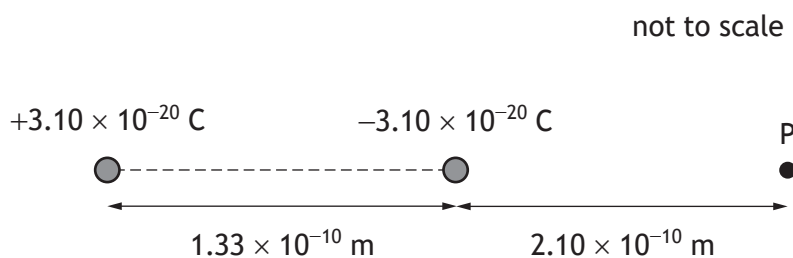

Figure 13B

Determine the electric potential at point P due to both charges.

4

Space for working and answer



13. (continued)

- (b) The charges in this model of the polar molecule produce an electric field.
 On **Figure 13C**, sketch the electric field pattern of this model.
 (An additional diagram, if required, can be found on page 55.).

2



Figure 13C

[Turn over



13. (continued)

(c) Liquid crystal displays use polar molecules placed in external electric fields.

A polar molecule is in a uniform electric field of strength 2550 NC^{-1} . This arrangement is shown in Figure 13D.

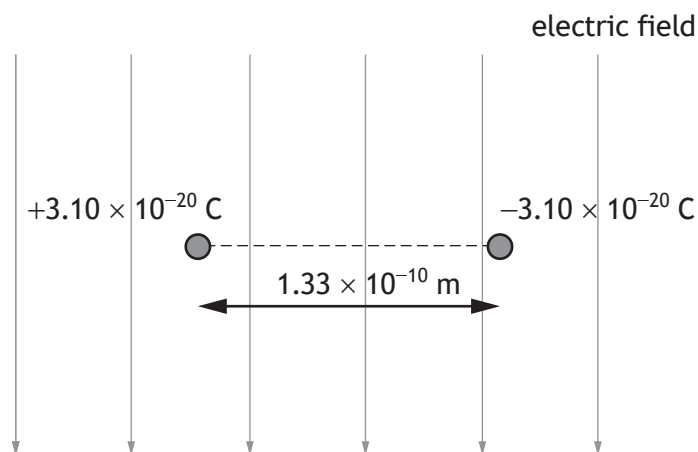

Figure 13D

Each charge experiences a force due to the electric field.

(i) Calculate the magnitude of the force acting on one of the charges.

3

Space for working and answer



13. (c) (continued)

(ii) The force acting on each charge causes the molecule to rotate about an axis of rotation midway between the charges. The axis of rotation is out of the page.

(A) Determine the initial magnitude of the resultant torque acting on the polar molecule.

4

Space for working and answer

(B) The polar molecule rotates from its starting position shown in **Figure 13D**.

State whether the unbalanced torque increases, remains the same or decreases as the polar molecule rotates through 90° .

Justify your answer.

2



* X 8 5 7 7 7 0 1 4 3 *

14. A student designs an experiment to determine the permeability of free space (μ_0) by measuring the magnetic induction around a current carrying wire. The experimental setup is shown in Figure 14A.

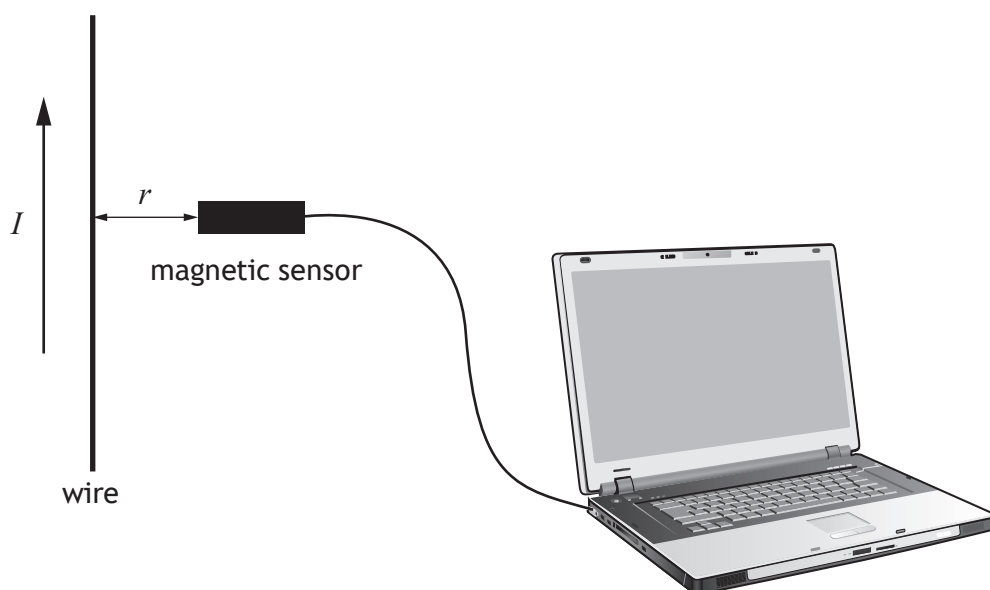

Figure 14A

The front of the magnetic sensor is positioned 0.010 m from the wire.

- (a) The student tests the setup using a current of 1.2 A in the wire. The student measures the magnetic induction due to the current in the wire to be 27 μT . Show that the value obtained for μ_0 is $1.4 \times 10^{-6} \text{ H m}^{-1}$.
Space for working and answer

2



14. (continued)

- (b) The current in the wire is now varied and the magnetic induction is measured using the magnetic sensor.

The data from the experiment are plotted on a graph using a spreadsheet package.

The graph is shown in **Figure 14B**.

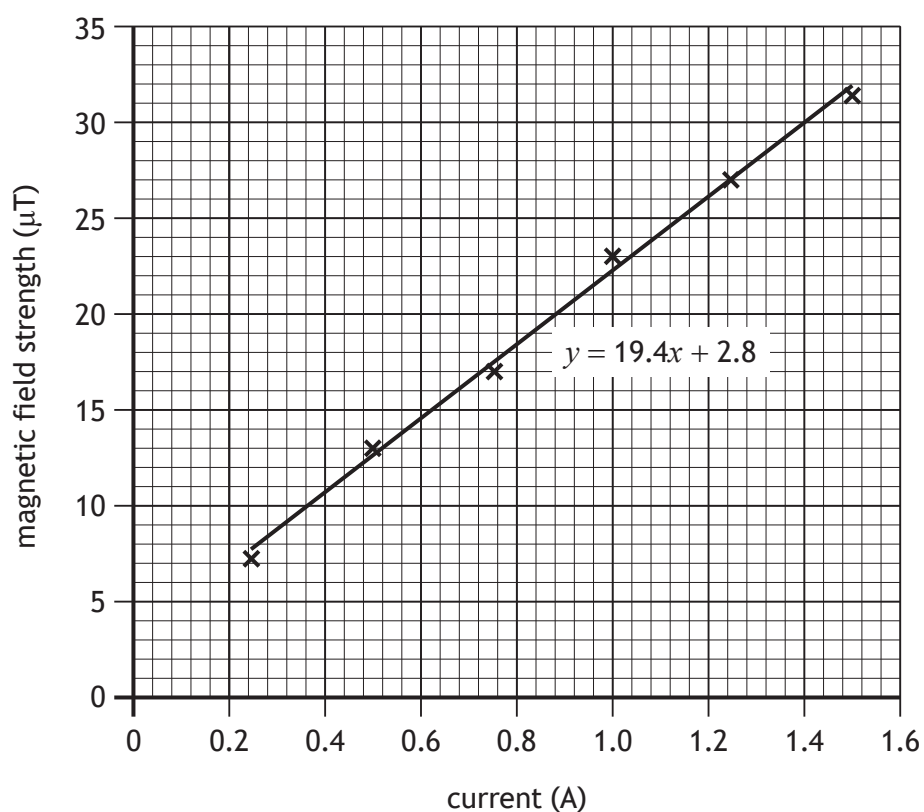

Figure 14B

- (i) Using information from the graph, determine a value for μ_0 .

3

Space for working and answer

[Turn over



* X 8 5 7 7 7 0 1 4 5 *

14. (b) (continued)

MARKS DO NOT WRITE IN THIS MARGIN

(ii) Explain why the student should have more confidence in the value obtained for μ_0 in (b) (i).

1

(iii) Data from the graphing software are shown below.

Gradient	y -intercept
19.4	2.8
Uncertainty in gradient	Uncertainty in y -intercept
0.6	0.7

The uncertainty in the measurement of the distance from the front of the sensor to the wire is 0.0005 m.

Calculate the absolute uncertainty in the value of μ_0 obtained by the student in (b) (i).

3

Space for working and answer

(iv) The line of best fit does not pass through the origin as theory predicts. Suggest a source for this systematic uncertainty.

1



15. A technician designs a circuit that will make a neon lamp flash. This circuit is shown in Figure 15A.

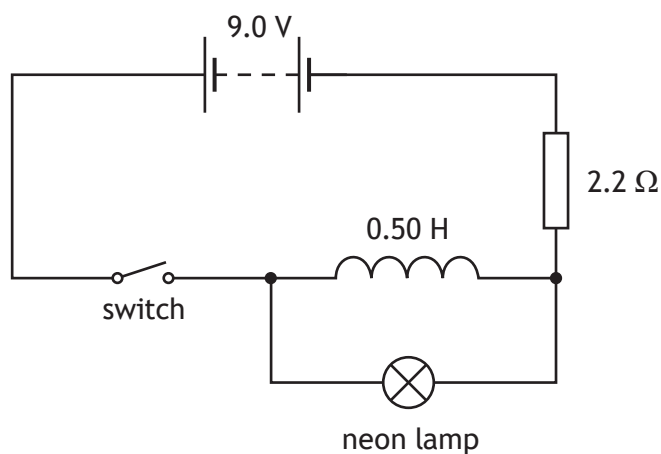

Figure 15A

The inductor has an inductance of 0.50 H and negligible resistance.

- (a) The switch is closed and a back EMF is induced.

Explain how the back EMF is induced.

1

- (b) In the inductor circuit, the time constant τ is the time taken for the current to reach 63% of the maximum value.

The time constant is given by the relationship

$$\tau = \frac{L}{R}$$

- (i) Calculate the time constant for the circuit.

2

Space for working and answer



15. (b) (continued)

- (ii) The back EMF across the inductor varies with time from the instant the switch is closed. This is shown on the graph in Figure 15B.

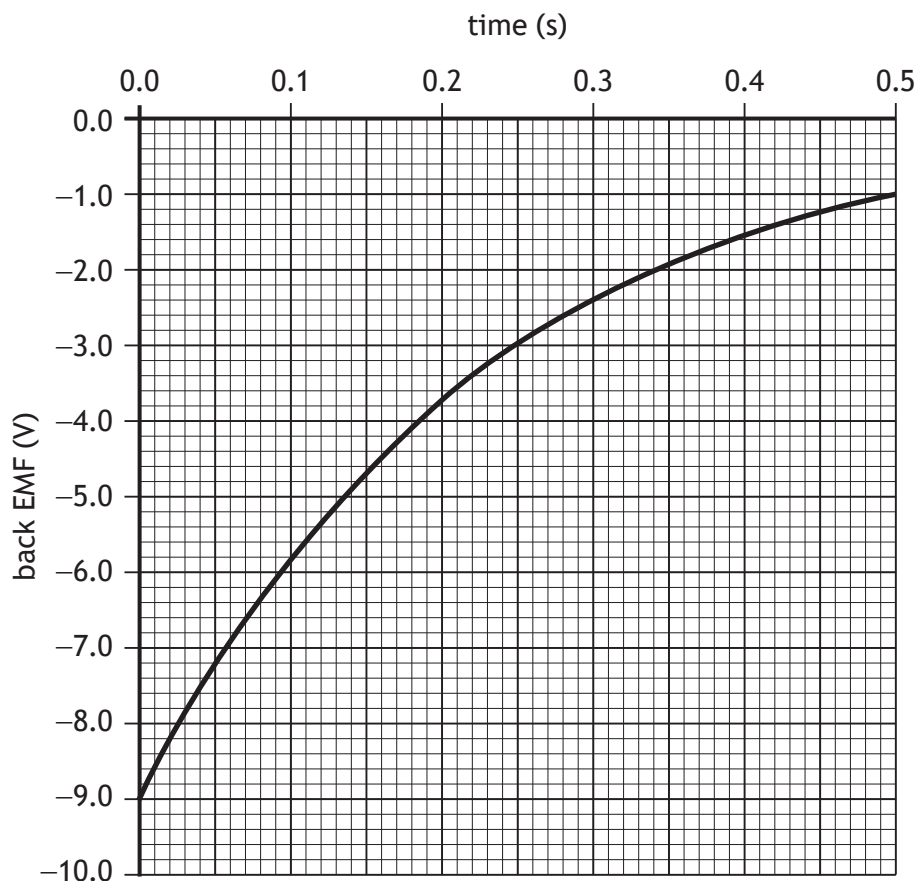

Figure 15B

Determine the rate of change of current in the circuit after one time constant.

Space for working and answer

4



15. (continued)

- (c) The neon lamp requires a potential difference of 80 V to conduct.

The switch is opened and the neon lamp flashes.

By considering the magnetic field around the inductor, explain why the back EMF produced is large enough to allow the neon lamp to flash.

1

- (d) The switch is replaced by an automatic switch.

This switch is closed. After **five time constants** the switch opens automatically. The neon lamp flashes immediately when the switch opens and then the switch closes again. This cycle repeats and the neon lamp flashes at regular intervals.

- (i) Determine the frequency at which the neon lamp flashes.

2

Space for working and answer

- (ii) The technician increases the inductance of the inductor and keeps all other components the same.

State whether the frequency of the flashes will increase, stay the same or decrease.

You must justify your answer.

2

[Turn over



* X 8 5 7 7 7 0 1 4 9 *

16. It is suggested that, around the year 1900, Lord Kelvin stated there was nothing new left to be discovered in physics and all that remained was more and more precise measurement.

Using your knowledge of physics, comment on this statement.

3



* X 8 5 7 7 7 0 1 5 0 *

16. (continued)

[END OF QUESTION PAPER]



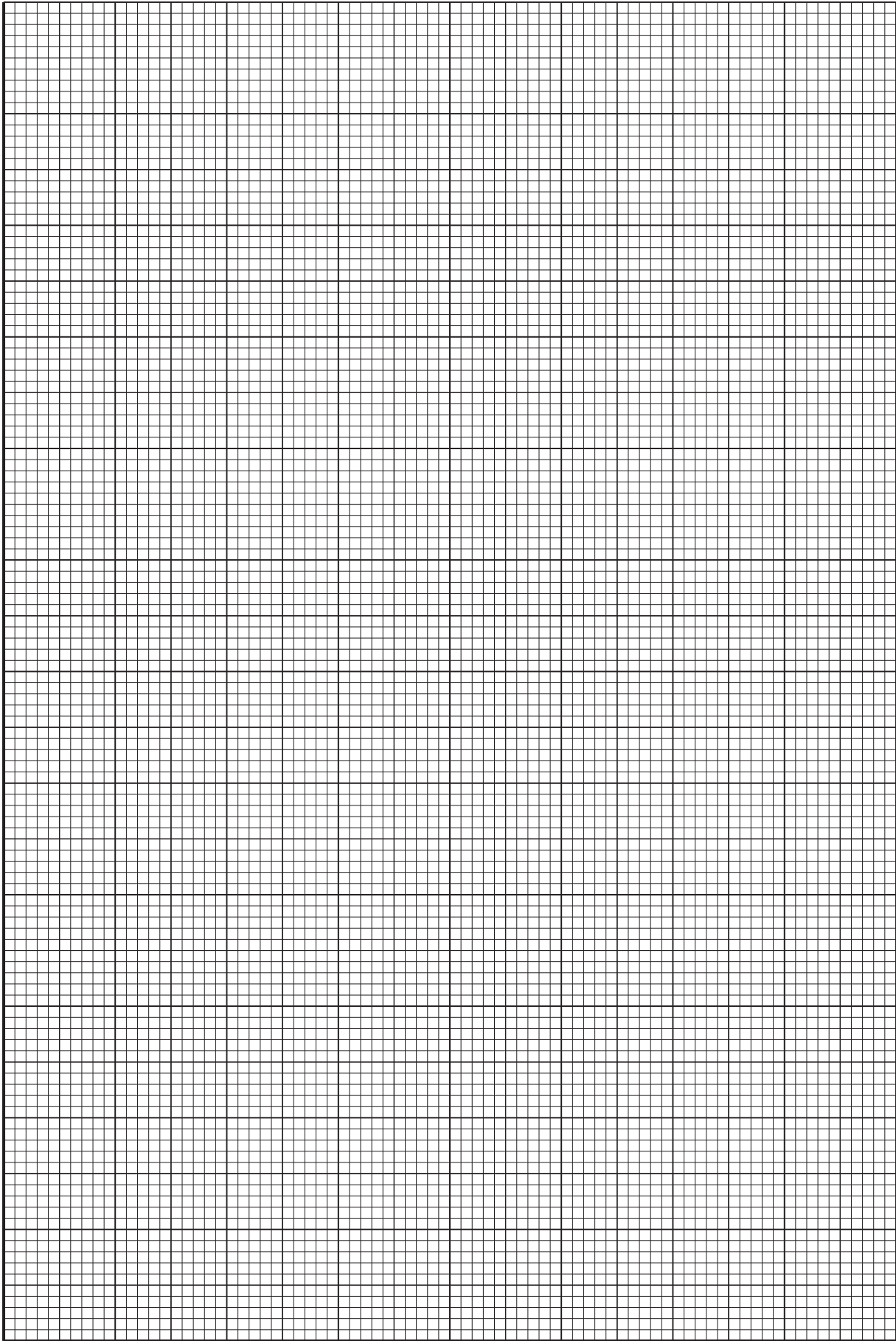

* X 8 5 7 7 7 0 1 5 2 *

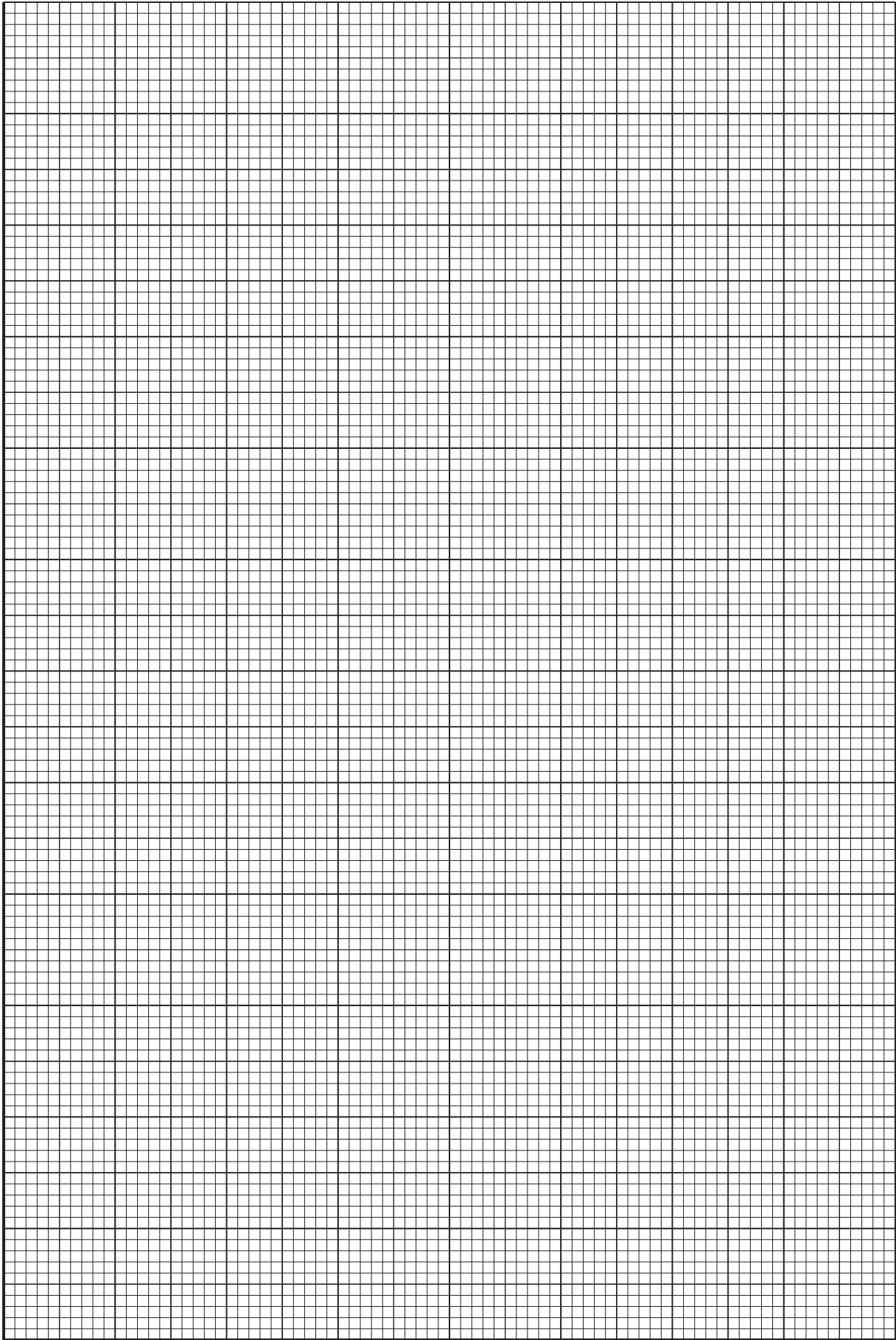

ADDITIONAL SPACE FOR ANSWERS AND ROUGH WORK

Additional diagram for use with question 6 (e)

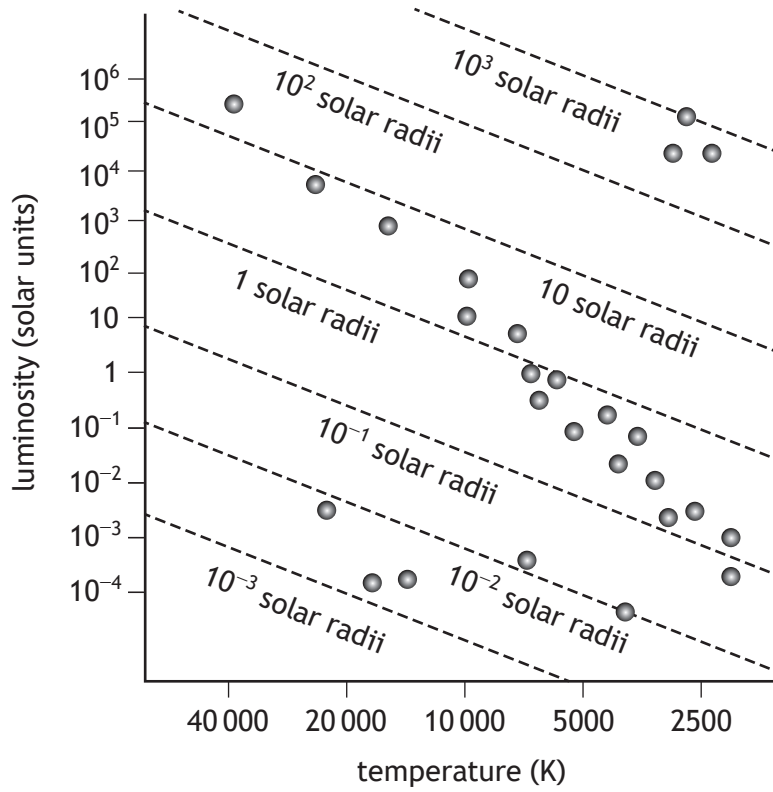

Additional graph for use with question 10 (f)

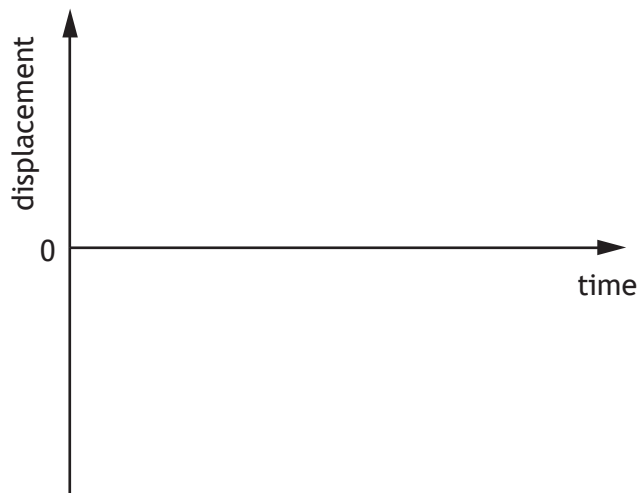

ADDITIONAL SPACE FOR ANSWERS AND ROUGH WORK

Additional diagram for use with question 11 (c)

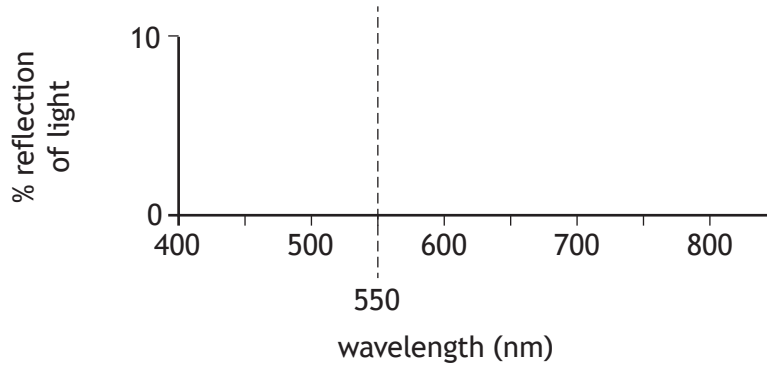

Additional diagram for use with question 13 (b)



MARKS DO NOT
WRITE IN
THIS
MARGIN

ADDITIONAL SPACE FOR ANSWERS AND ROUGH WORK



* X 8 5 7 7 7 0 1 5 6 *

MARKS DO NOT
WRITE IN
THIS
MARGIN

ADDITIONAL SPACE FOR ANSWERS AND ROUGH WORK



* X 8 5 7 7 7 0 1 5 7 *

[BLANK PAGE]

DO NOT WRITE ON THIS PAGE



* X 8 5 7 7 7 0 1 5 8 *

[BLANK PAGE]

DO NOT WRITE ON THIS PAGE



* X 8 5 7 7 7 0 1 5 9 *

[BLANK PAGE]

DO NOT WRITE ON THIS PAGE

Acknowledgement of copyright

- Question 2 Vectorpocket/shutterstock.com
Question 4 Dima Zel/shutterstock.com
Question 5 Julia Kopacheva/shutterstock.com

